

ALL-TERRAIN
RTF 40-3

ISO 9001

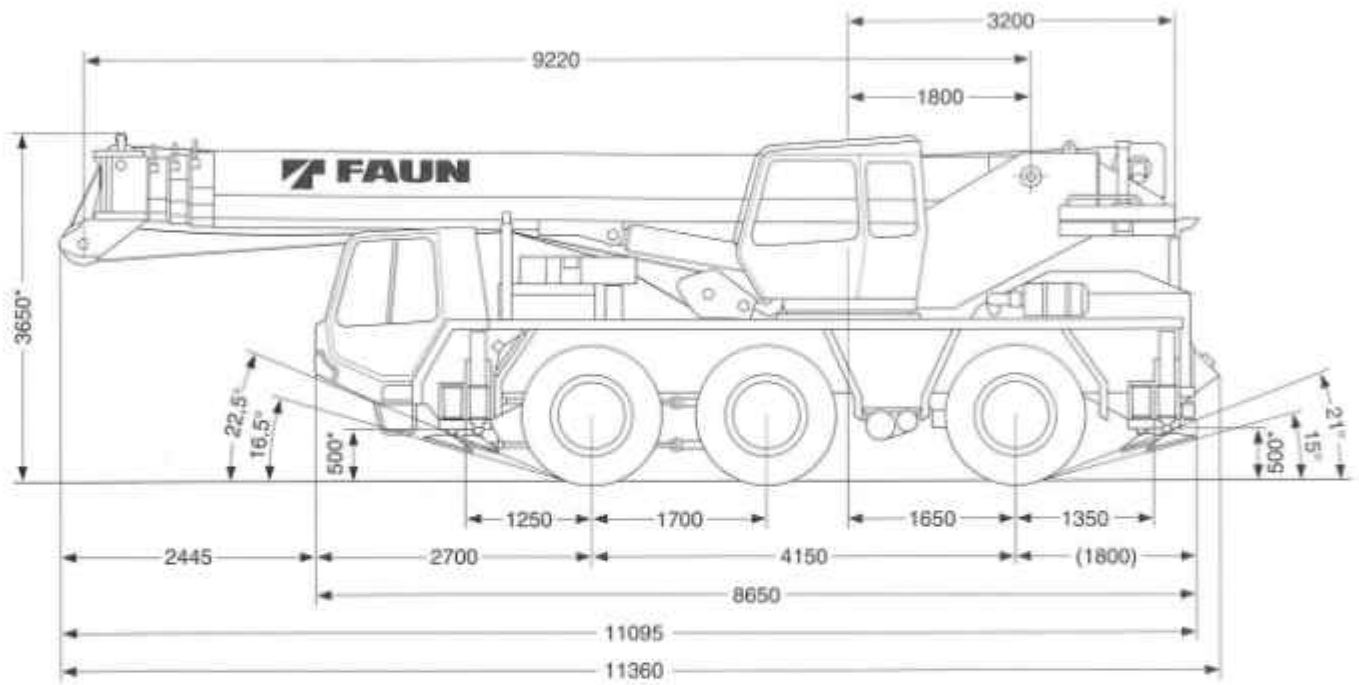

Maße / Dimensions / Dimensions / Dimensiones (mm)
 Gewichte / Weights / Poids / Pesos
 Geschwindigkeiten / Speeds / Vitesses / Velocidades

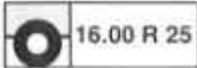

*) +/- 100 mm

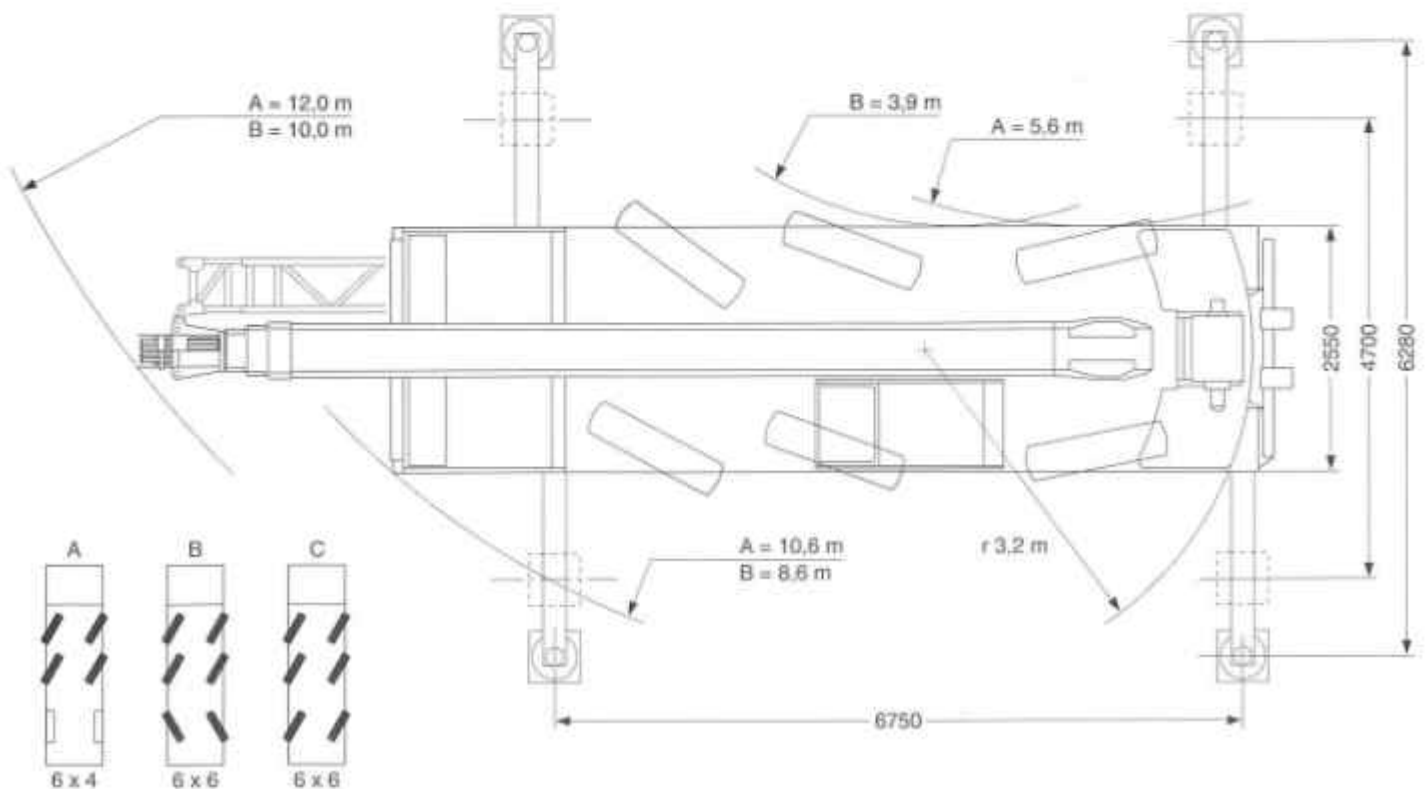

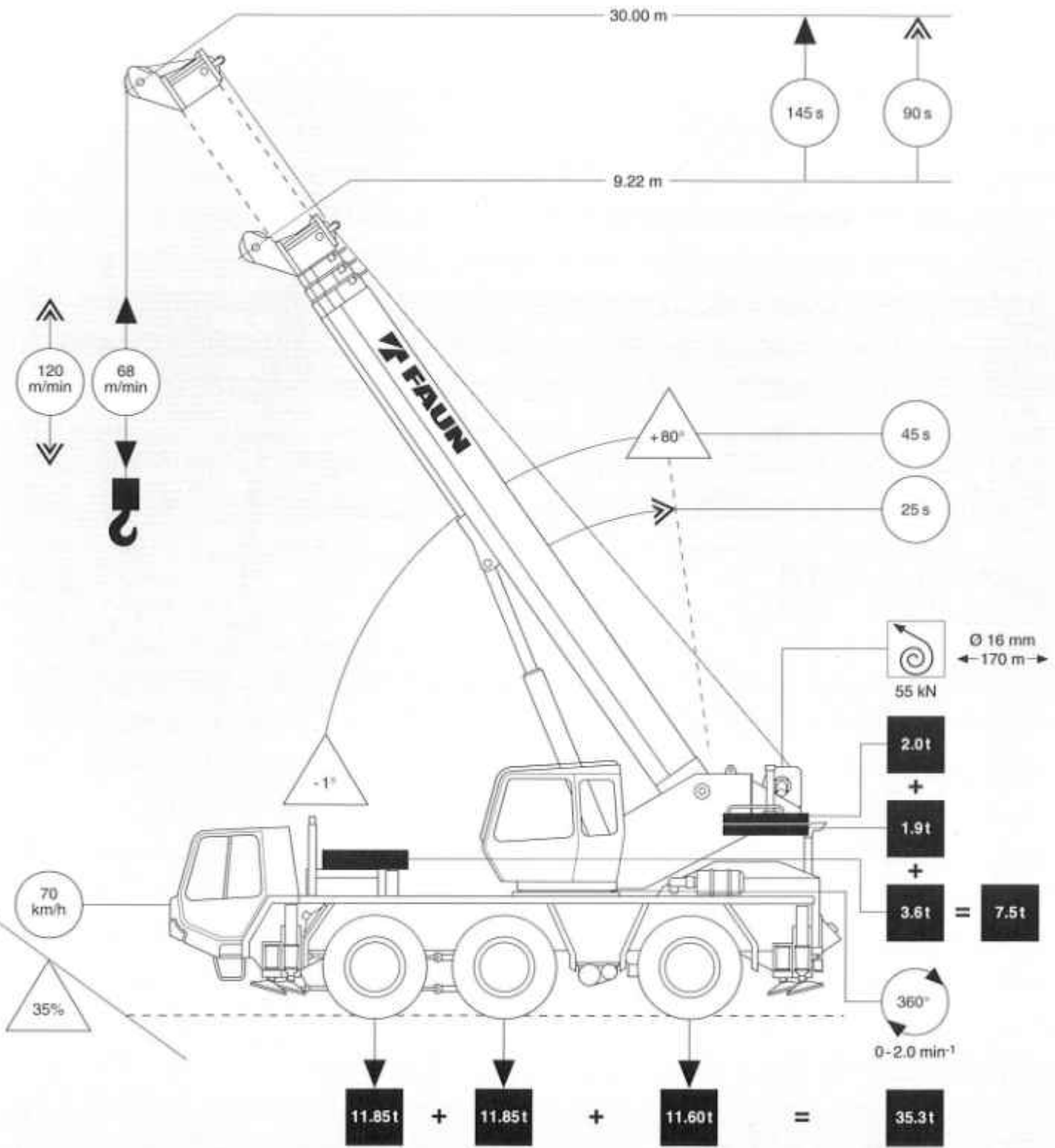
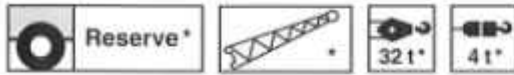

Tragfähigkeiten am Teleskopausleger
 Lifting capacities on telescopic boom
 Capacités de levage sur la flèche télescopique
 Capacidades de elevación con la pluma telescópica



9.6t*

DIN

m	9.22 m	16.10 m	23.00 m	28.50 m	30.00 m
2.5	40.00**				
3.0	35.00				
3.5	31.70				
4.0	29.00	22.00			
4.5	26.50	22.00			
5.0	23.80	22.00	15.00	11.00	
6.0	19.60	19.30	15.00	11.00	10.00
7.0	16.60	16.20	14.00	11.00	10.00
8.0		14.00	12.60	10.50	9.70
9.0		12.20	10.90	10.00	9.30
10.0		10.70	9.80	9.10	8.70
11.0		9.50	8.70	8.30	8.00
12.0		8.50	7.90	7.60	7.40
14.0		7.00	6.60	6.40	6.30
16.0			5.50	5.40	5.50
18.0			4.40	4.70	4.70
20.0			3.50	3.90	4.00
22.0				3.20	3.30
24.0				2.60	2.80
26.0				2.20	2.30
27.0					2.10



0

0

0

50

50

0

100

100

0

100

100

80

100

100

100



9.6t*

85%

m	9.22 m	16.10 m	23.00 m	28.50 m	30.00 m
2.5	40.00**				
3.0	40.00**				
3.5	33.90				
4.0	31.00	23.60			
4.5	28.40	23.60			
5.0	25.50	23.60	16.20	11.90	
6.0	21.05	20.80	16.20	11.90	10.85
7.0	17.85	17.50	15.15	11.90	10.85
8.0		15.10	13.65	11.40	10.50
9.0		13.20	11.85	10.85	10.10
10.0		11.60	10.65	9.90	9.45
11.0		10.30	9.50	9.05	8.70
12.0		9.30	8.65	8.30	8.05
14.0		7.65	7.25	7.00	6.90
16.0			6.10	5.95	6.05
18.0			4.95	5.20	5.20
20.0			3.95	4.35	4.45
22.0				3.65	3.75
24.0				3.05	3.20
26.0				2.60	2.70
27.0					2.50



0

0

0

50

50

0

100

100

0

100

100

80

100

100

100

Hubhöhen
Lifting heights
Hauteurs de levage
Alturas de elevación



9.6t*

DIN

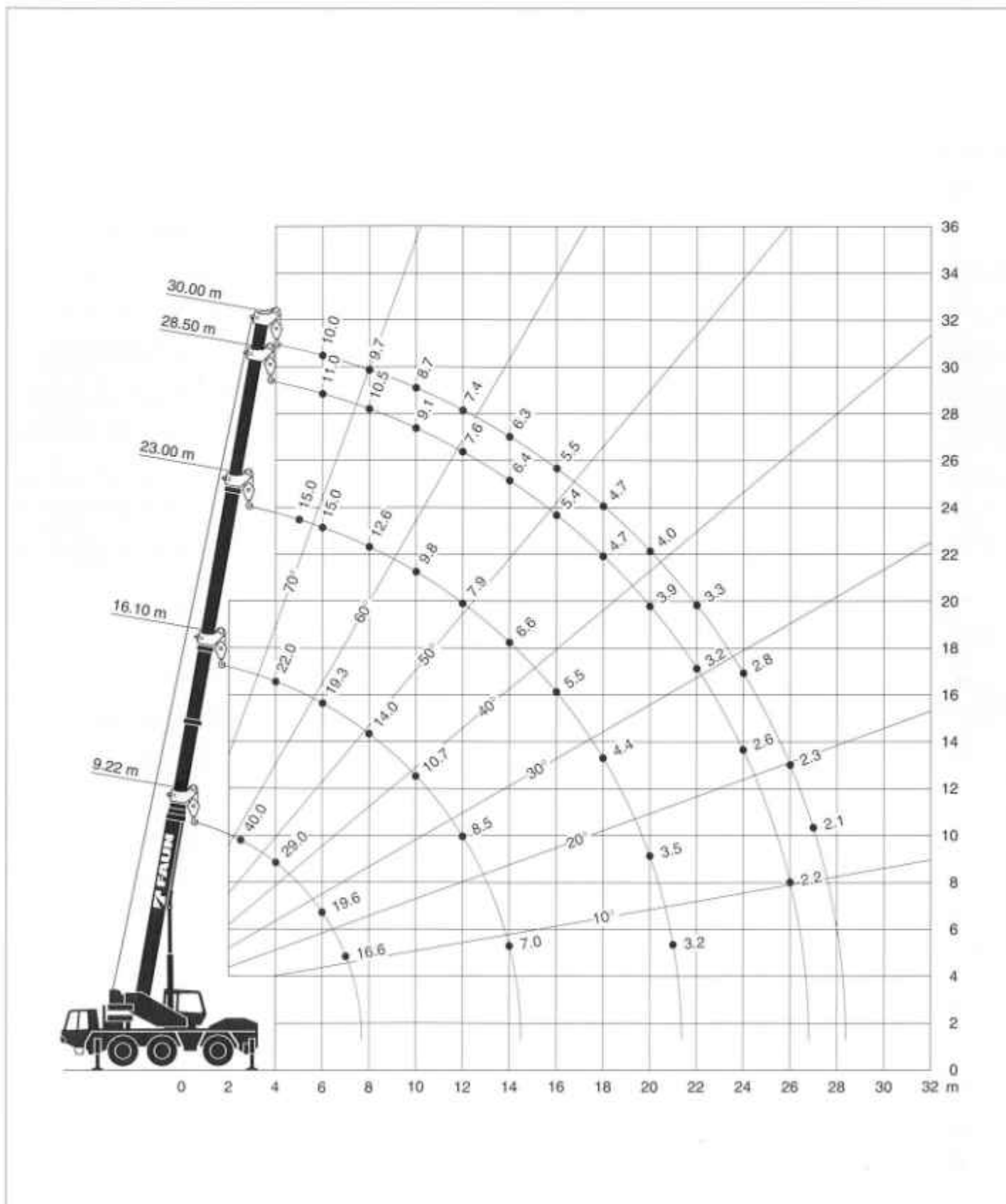

*) Gegen Mehrpreis
*) Against extra charge

*) Contre supplément de prix
*) Con suplemento de precio

**) Mit Zusatzausrüstung
**) With additional equipment

**) Avec équipement supplémentaire
**) Con equipo adicional

Tragfähigkeiten am Teleskopausleger
 Lifting capacities on telescopic boom
 Capacités de levage sur la flèche télescopique
 Capacidades de elevación con la pluma telescópica



7.5t

DIN

↘ m	9.22 m	16.10 m	16.10 m	16.10 m	23.00 m	23.00 m	28.50 m	30.00 m
2.5	40.00*							
3.0	35.00							
3.5	31.50							
4.0	28.40	22.00	15.00	15.00				
4.5	25.10	22.00	15.00	15.00				
5.0	22.50	22.00	15.00	15.00	15.00	10.00	11.00	
6.0	18.50	18.10	15.00	14.60	15.00	10.00	11.00	10.00
7.0	15.60	15.30	15.00	12.90	14.00	9.60	11.00	10.00
8.0		13.10	12.60	11.60	12.60	8.60	10.50	9.70
9.0		11.40	10.90	10.50	10.90	7.70	10.00	9.30
10.0		10.00	9.60	9.60	9.80	7.00	9.10	8.70
11.0		8.90	8.50	8.80	8.70	6.40	8.30	8.00
12.0		8.00	7.50	8.20	7.70	5.90	7.60	7.40
14.0		6.10	5.50	6.50	5.80	5.10	6.30	6.30
16.0					4.50	4.50	4.90	5.00
18.0					3.50	3.90	3.90	4.00
20.0					2.80	3.50	3.20	3.30
22.0							2.60	2.70
24.0							2.10	2.20
26.0							1.70	1.80
27.0								1.60

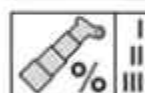

I
II
III

I	0	50	100	0	100	0	100	100
II	0	50	0	100	100	100	100	100
III	0	0	0	0	0	100	80	100



7.5t

85%

↘ m	9.22 m	16.10 m	16.10 m	16.10 m	23.00 m	23.00 m	28.50 m	30.00 m
2.5	40.00*							
3.0	40.00*							
3.5	33.70							
4.0	30.40	23.60	16.20	16.20				
4.5	26.90	23.60	16.20	16.20				
5.0	24.10	23.60	16.20	16.20	16.20	10.85	11.90	
6.0	19.90	19.50	16.20	15.70	16.20	10.85	11.90	10.85
7.0	16.80	16.50	16.20	13.95	15.15	10.40	11.90	10.85
8.0		14.15	13.65	12.55	13.65	9.35	11.40	10.50
9.0		12.35	11.85	11.40	11.85	8.40	10.85	10.10
10.0		10.85	10.50	10.45	10.65	7.65	9.90	9.45
11.0		9.70	9.30	9.60	9.50	7.00	9.05	8.70
12.0		8.75	8.25	8.90	8.45	6.45	8.30	8.10
14.0		6.70	6.10	7.10	6.40	5.60	6.90	6.90
16.0					5.05	5.00	5.45	5.55
18.0					4.00	4.35	4.35	4.45
20.0					3.25	3.90	3.65	3.70
22.0							3.00	3.10
24.0							2.45	2.55
26.0							2.05	2.10
27.0								1.90



I
II
III

I	0	50	100	0	100	0	100	100
II	0	50	0	100	100	100	100	100
III	0	0	0	0	0	100	80	100

Hubhöhen
Lifting heights
Hauteurs de levage
Alturas de elevación

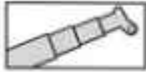

7.5t

DIN

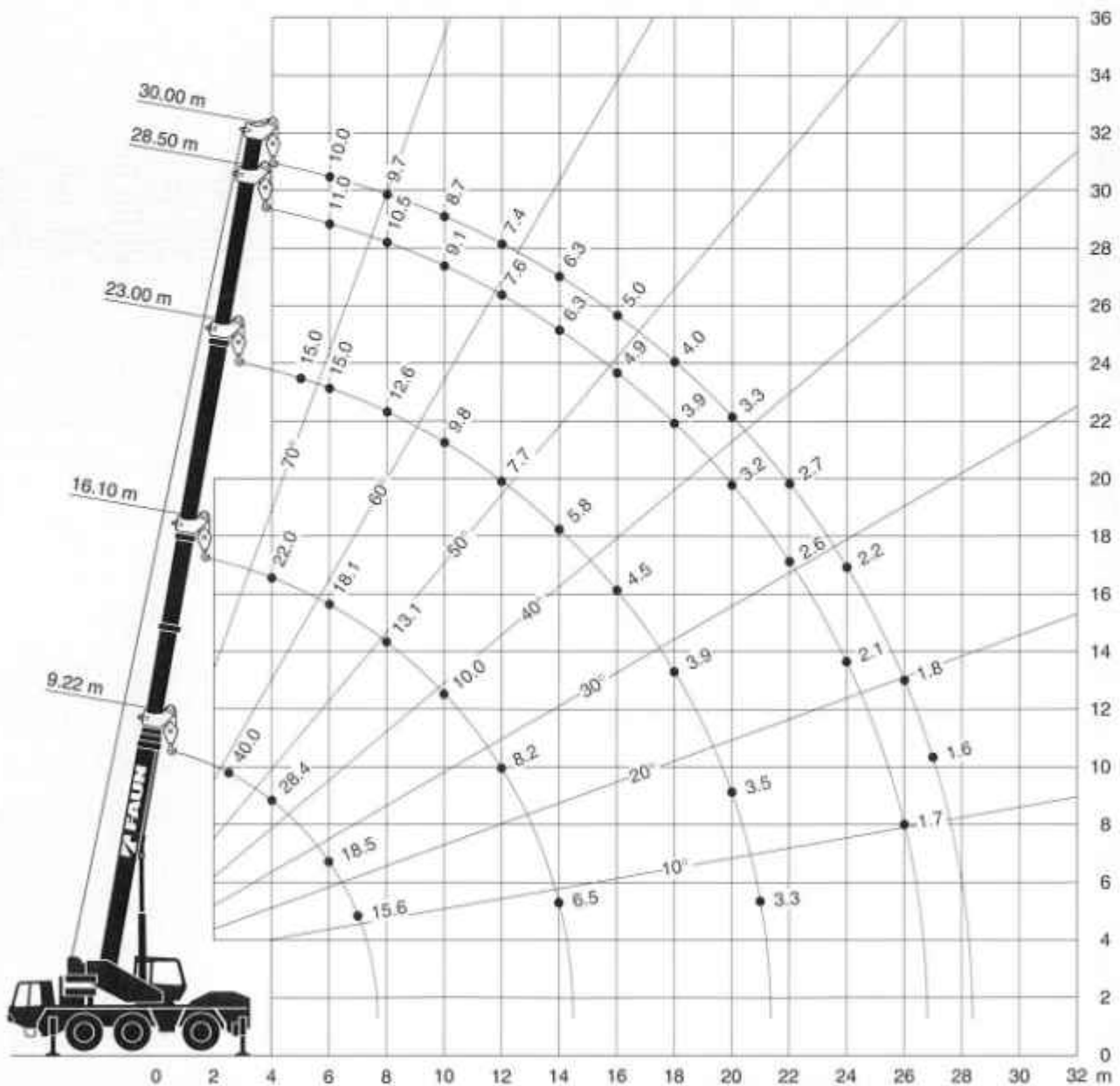

Tragfähigkeiten an der Spitze*
 Lifting capacities on boom extension*
 Capacités de levage sur rallonge de flèche*
 Capacidades de elevación con plumín*

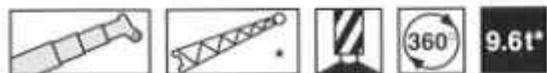

DIN

m	30.00 m + 9.05 m			30.00 m + 8.70 m			30.00 m + 15.45 m		
	0°	15°	30°	0°	15°	30°	0°	15°	30°
8.0	4.50			4.70					
9.0	4.44			4.57					
10.0	4.30	3.34		4.41	3.42		2.60		
11.0	4.17	3.24		4.27	3.31		2.60		
12.0	4.04	3.14	2.51	4.14	3.20	2.58	2.59	1.84	
14.0	3.78	2.95	2.40	3.87	3.02	2.46	2.26	1.75	
16.0	3.50	2.77	2.30	3.59	2.85	2.36	2.01	1.61	1.38
18.0	3.26	2.62	2.20	3.32	2.69	2.27	1.89	1.47	1.26
20.0	3.00	2.48	2.10	2.97	2.55	2.16	1.80	1.39	1.14
22.0	2.70	2.33	2.00	2.69	2.39	2.05	1.67	1.31	1.07
24.0	2.46	2.18	1.91	2.41	2.23	1.97	1.53	1.22	1.02
26.0	2.25	2.06	1.83	2.21	2.05	1.89	1.41	1.14	0.96
28.0	2.05	1.95	1.76	2.01	1.90	1.83	1.32	1.08	0.91
30.0	1.75	1.80	1.71	1.65	1.77	1.72	1.23	1.03	0.88
32.0	1.45	1.50	1.55	1.35	1.45	1.45	1.14	0.97	0.84
34.0	1.20	1.25	1.25	1.10	1.15	1.15	1.05	0.91	0.81
36.0	1.00	1.00		0.90	0.95		0.96	0.86	0.78
38.0							0.85	0.80	0.74
40.0							0.65	0.74	0.70
42.0							0.45	0.55	0.50
43.0							0.35	0.40	
		100			100			100	
		100			100			100	
		100			100			100	

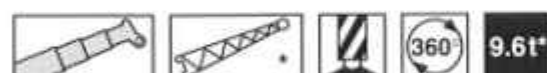

85%

m	30.00 m + 9.05 m			30.00 m + 8.70 m			30.00 m + 15.45 m		
	0°	15°	30°	0°	15°	30°	0°	15°	30°
8.0	5.00			5.20					
9.0	4.90			5.10					
10.0	4.80	3.70		4.90	3.80		3.00		
11.0	4.60	3.60		4.80	3.70		3.00		
12.0	4.50	3.50	2.90	4.60	3.60	2.90	2.90	2.20	
14.0	4.20	3.30	2.70	4.30	3.40	2.80	2.60	2.10	
16.0	3.90	3.10	2.60	4.00	3.20	2.70	2.30	1.90	1.70
18.0	3.70	3.00	2.50	3.70	3.10	2.60	2.20	1.80	1.60
20.0	3.40	2.80	2.40	3.40	2.90	2.50	2.10	1.70	1.40
22.0	3.10	2.70	2.30	3.10	2.70	2.40	2.00	1.60	1.40
24.0	2.80	2.50	2.20	2.75	2.60	2.30	1.80	1.50	1.30
26.0	2.55	2.40	2.10	2.55	2.35	2.20	1.70	1.40	1.20
28.0	2.35	2.20	2.10	2.30	2.15	2.10	1.60	1.40	1.20
30.0	2.00	2.05	1.95	1.90	2.00	1.95	1.50	1.30	1.10
32.0	1.65	1.70	1.75	1.55	1.65	1.65	1.30	1.20	1.10
34.0	1.35	1.40	1.40	1.25	1.30	1.30	1.20	1.20	1.10
36.0	1.15	1.15		1.00	1.05		1.10	1.00	1.00
38.0							0.95	0.90	0.85
40.0							0.80	0.86	0.80
42.0							0.70	0.70	0.70
43.0							0.60	0.65	
		100			100			100	
		100			100			100	
		100			100			100	

Hubhöhen
Lifting heights
Hauteurs de levage
Alturas de elevación



DIN

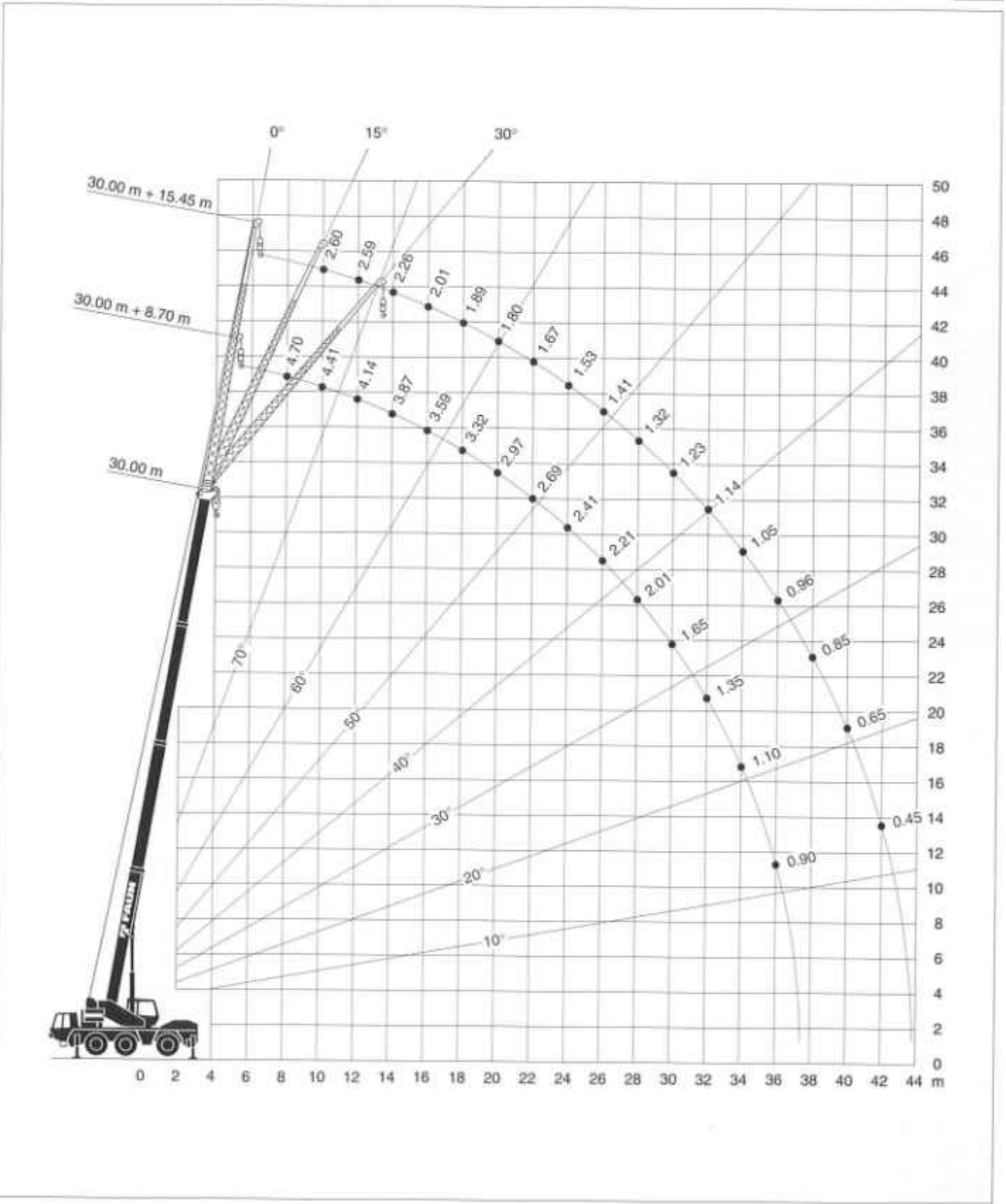



*) Gegen Mehrpreis *) Against extra charge *) Contre supplément de prix *) Con suplemento de precio

Tragfähigkeiten an der Spitze*
 Lifting capacities on boom extension*
 Capacités de levage sur rallonge de flèche*
 Capacidades de elevación con plumín*





DIN

 m	30.00 m + 9.05 m			30.00 m + 8.70 m			30.00 m + 15.45 m		
	0°	15°	30°	0°	15°	30°	0°	15°	30°
8.0	4.50			4.70					
9.0	4.44			4.57					
10.0	4.30	3.34		4.41	3.42		2.60		
11.0	4.17	3.24		4.27	3.31		2.60		
12.0	4.04	3.14	2.51	4.14	3.20	2.58	2.59	1.84	
14.0	3.78	2.95	2.40	3.87	3.02	2.46	2.26	1.75	
16.0	3.50	2.77	2.30	3.59	2.85	2.36	2.01	1.61	1.38
18.0	3.25	2.62	2.20	3.32	2.69	2.27	1.89	1.47	1.26
20.0	3.00	2.48	2.10	2.97	2.55	2.16	1.80	1.39	1.14
22.0	2.70	2.33	2.00	2.69	2.39	2.05	1.67	1.31	1.07
24.0	2.46	2.18	1.91	2.25	2.23	1.97	1.53	1.22	1.02
26.0	2.00	2.06	1.83	1.85	1.95	1.89	1.41	1.14	0.96
28.0	1.70	1.83	1.76	1.50	1.60	1.65	1.32	1.08	0.91
30.0	1.40	1.45	1.53	1.15	1.25	1.31	1.23	1.03	0.88
32.0	1.10	1.20	1.22	0.90	1.00	1.00	1.05	0.97	0.84
34.0	0.90	0.95	0.95	0.70	0.72	0.75	0.81	0.91	0.81
36.0	0.70	0.70		0.50	0.50		0.61	0.75	0.78
38.0							0.44	0.55	0.60
40.0								0.35	0.38
42.0									
44.0									
 I II III		100			100			100	
		100			100			100	
		100			100			100	



85%

 m	30.00 m + 9.05 m			30.00 m + 8.70 m			30.00 m + 15.45 m		
	0°	15°	30°	0°	15°	30°	0°	15°	30°
8.0	5.00			5.20					
9.0	4.90			5.10					
10.0	4.80	3.70		4.90	3.80		3.00		
11.0	4.60	3.60		4.80	3.70		3.00		
12.0	4.50	3.50	2.90	4.60	3.60	2.90	2.90	2.20	
14.0	4.20	3.30	2.70	4.30	3.40	2.80	2.60	2.10	
16.0	3.90	3.10	2.60	4.00	3.20	2.70	2.30	1.90	1.70
18.0	3.70	3.00	2.50	3.70	3.10	2.60	2.20	1.80	1.60
20.0	3.40	2.80	2.40	3.40	2.90	2.50	2.10	1.70	1.40
22.0	3.10	2.70	2.30	3.10	2.70	2.40	2.00	1.60	1.40
24.0	2.80	2.50	2.20	2.80	2.60	2.30	1.80	1.50	1.30
26.0	2.35	2.40	2.10	2.20	2.30	2.20	1.70	1.40	1.20
28.0	2.00	2.15	2.10	1.80	1.90	2.00	1.60	1.40	1.20
30.0	1.70	1.75	1.85	1.50	1.60	1.60	1.50	1.30	1.10
32.0	1.35	1.50	1.50	1.20	1.30	1.30	1.30	1.20	1.10
34.0	1.15	1.20	1.20	1.00	1.00	1.00	1.10	1.20	1.10
36.0	0.95	0.95		0.70	0.80		0.90	1.00	1.00
38.0							0.70	0.80	0.80
40.0								0.60	0.60
42.0									
44.0									
 I II III		100			100			100	
		100			100			100	
		100			100			100	

Hubhöhen
Lifting heights
Hauteurs de levage
Alturas de elevación

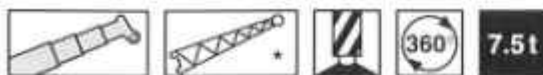

DIN

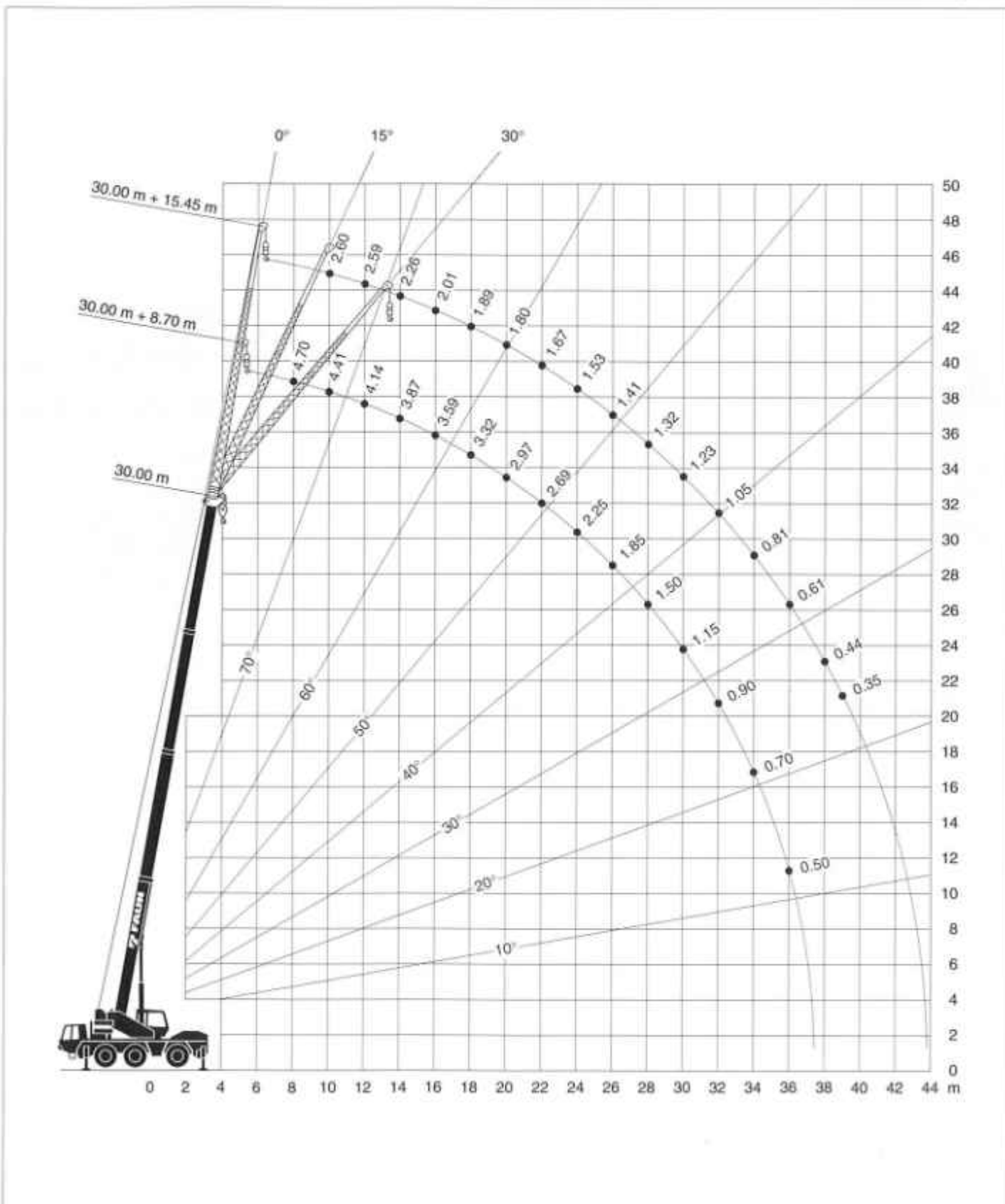

Tragfähigkeiten am Teleskopausleger Lifting capacities on telescopic boom Capacités de levage sur la flèche télescopique Capacidades de elevación con la pluma telescópica

		7.5t	9.6t*	DIN
				
	m	9.22 m	16.10 m	
2.5		15.10		
3.0		15.10		
3.5		13.40		
4.0		12.00	12.00	
4.5		10.80	10.80	
5.0		9.80	9.80	
6.0		8.10	8.20	
7.0		7.00	7.00	
8.0			6.00	
9.0			5.20	
10.0			4.60	
11.0			4.00	
12.0			3.60	
14.0			2.70	
	I	0	0	
	II	0	100	
	III	0	0	

		7.5t	9.6t*	85%
				
	m	9.22 m	16.10 m	
2.5		16.20		
3.0		16.20		
3.5		14.45		
4.0		12.95	12.95	
4.5		11.70	11.65	
5.0		10.60	10.60	
6.0		8.80	8.90	
7.0		7.65	7.65	
8.0			6.55	
9.0			5.70	
10.0			5.10	
11.0			4.45	
12.0			4.00	
14.0			3.00	
	I	0	0	
	II	0	100	
	III	0	0	

Anmerkungen zu den Traglasttabellen

Die Tragfähigkeiten im Festigkeitsbereich basieren auf DIN 15018 Blatt 2 und Blatt 3 und F.E.M.

Die Tragfähigkeiten im Standsicherheitsbereich entsprechen DIN 15019 Teil 2.

Die 85% Tragfähigkeitsangaben überschreiten nicht 85% der Kipplast. Dynamische Einflüsse und Wind reduzieren die Tragfähigkeiten. Die 85% Tragfähigkeitsangaben entsprechen nicht den Sicherheitsanforderungen der EG-Maschinen-Richtlinie.

Die zulässige Windgeschwindigkeit beträgt maximal 15 m/sec.

Die Tragfähigkeiten sind in metrischen Tonnen angegeben.

Das Gewicht des Lasthakens bzw. der Hakenflasche und weiterer Anschlagmittel ist von der Tragfähigkeit abzuziehen.

Die Tragfähigkeiten für den Teleskopausleger gelten nur bei demontierter Spitze.

Die Ausladung ist der horizontale Abstand von Mitte Drehkranz bis Mitte freihängender, nicht schwingender Last.

Tragfähigkeitsänderungen vorbehalten.

Obige Angaben dienen nur zur Information. Die Bedienungsanleitungen müssen zu Rate gezogen werden, bevor die Maschine in Betrieb genommen wird. Alle hier gemachten Angaben beziehen sich auf die Standard-Ausführung. Jegliche Ausrüstungsveränderungen können die angegebenen Werte beeinflussen.

Remarks concerning the load charts

The lifting capacities in the structural area are based on DIN 15018 parts 2 and 3 and F.E.M.

The lifting capacities in the stability area are based on DIN 15019 part 2.

The 85% lifting capacities do not exceed 85% of tipping load. Dynamic influences and wind reduce the lifting capacities.

The 85% lifting capacities do not comply with the safety requirements of the EEC Machinery Directive.

The maximum permissible wind speed for crane operation is 15 m/sec.

The lifting capacities shown are in metric tons.

The weight of load handling devices such as hook blocks, slings, etc., must be considered as part of the load and must be deducted from the lifting capacities.

The lifting capacities for the telescopic boom apply to a crane with no boom extensions being stowed or mounted on the crane.

The working radius is the horizontal distance from the centre of rotation to the centre of the freely suspended non-oscillating load.

The lifting capacities are subject to change without prior notice.

The above remarks are for basic information only and the operator's manual must be consulted before operating this crane. All data and performances refer to the standard crane. The addition of optional and other equipment may affect the performance of the crane.

Remarques relatives aux tableaux des charges

Les forces de levage sont conformes aux normes DIN 15018, p. 2 et 3, et F.E.M.

Les forces de levage dans la partie de stabilité au renversement sont conformes aux normes DIN 15019, chap. 2.

Les charges de levage indiquées de 85% ne dépassent pas 85% de la charge de renversement. Les influences dynamiques et le vent réduisent les charges de levage. Les charges de levage indiquées de 85% ne correspondent pas aux exigences de sécurité de la directive CE relative aux machines.

La grue peut travailler aux vitesses de vent allant jusqu'à 15 m/s.

Les forces de levage sont données en tonnes métriques.

Le poids du crochet-moufle et de tous les accessoires d'élingage font partie de la charge et sont à déduire des charges indiquées.

Les forces de levage indiquées pour la flèche télescopique s'entendent flèche déposée.

Comme portée, on entend la distance horizontale du centre de la couronne de rotation au centre de la charge librement suspendue et non oscillante.

Sauf modification de forces de levage.

Les données ci-dessus servent à titre d'information. Avant la mise en marche de la grue il est conseillé d'étudier les instructions de service. Toutes les données indiquées ci-dessus se réfèrent à la machine de base. Tout changement de l'équipement de la grue peut influencer ces valeurs.

Notas relativas a los graficos de carga

En cuanto a los datos referentes a resistencia, las capacidades de carga están basados sobre las normas DIN 15018, págs. 2 y 3, y F.E.M.

En cuanto a los datos referentes a estabilidad anti-vuelco, las capacidades de carga están basados sobre las normas DIN 15019, Cap. 2.

Las indicaciones acerca de la capacidad de carga del 85% no superan el 85% de la carga de vuelco. Influencias dinámicas y del viento reducen las capacidades de carga. Las indicaciones acerca de la capacidad de carga del 85% no corresponden a las normas de seguridad según la directiva para máquinas de la CE.

La velocidad anemométrica max. admisible es de 15 m/seg.

Las capacidades de carga indicadas en las tablas corresponden a toneladas métricas.

Hay que deducir los pesos del gancho o del motón y de otros dispositivos para fijación de cargas de los valores de capacidad de carga indicados en las tablas.

Las capacidades de carga referentes a la pluma telescópica rigen solamente si la punta está desmontada.

Como alcance se entiende la distancia horizontal desde el centro de la corona de rodaduras hasta el centro de la carga suspendida libremente y no oscilante.

Salvo modificación de capacidades de carga.

Los datos arriba indicados sirven solamente para su información. Hay que leer las instrucciones para el uso antes de la puesta en servicio de la máquina. Todos los datos mencionados en las presentes tablas rigen para los modelos standard. Cualquier modificación del equipo montado puede dar lugar a modificaciones de aquellos valores.



Rahmen

Verwindungs- und biegesteife Kastenkonstruktion.

Abstützung

4-Punkt vollhydraulisch. Betätigen vom Oberwagen sowie links und rechts am Fahrgestell, inklusive halbe Abstützbasis. Abstützbasis 6.28 m und 4.70 m.

Motor

Mercedes-Benz 6-Zyl. OM 401 LA (EURO 1), wassergekühlt, 213 kW (290 PS) bei 2100 U/min.
Drehmoment: 1180Nm (120 kpm) bei 1200 U/min.

Getriebe

ZF-Lastschaltgetriebe mit Drehmomentwandler und „Lock-up“ Kupplung (ab 1. Gang) mit 6 Vorwärts- und 1 Rückwärtsgang.

Antrieb

6 x 4 für Straßenfahrt
6 x 6 für Geländefahrt

Achsen

1. Achse: gelenkt, angetrieben, Differentialsperre quer.
2. Achse: gelenkt, angetrieben, Differentialsperre längs- und quer.
3. Achse: Einzelradaufhängung, gelenkt, angetrieben, Differentialsperre.

Achsaufhängung

Hydropneumatisch, elektro-hydraulisch blockierbar mit Niveauregulierung. Ein-/Ausfedern +/- 100 mm

Bremsen

Betriebsbremse: Druckluft-Zweikreis-Bremsanlage.
Feststellbremse: Federspeicher an 2. und 3. Achse.
Dauerbremse: Konstantdrossel-Anlage und Auspuffklappenbremse. Telma Bremse*

Bereifung

16.00 R 25 Straßen- und Geländeprofil.

Lenkung

Halbblock-Zweikreis-Hydraulienkung, gelenkt werden 1. und 2. Achse, hydraulisch unterstützt, mit Notlenkpumpe und Hundegang. Lenkung aller Achsen möglich.

Unterswagenkabine

Zwei-Mann-Fahrerhaus in Stahl-GFK-Verbundkonstruktion, Sicherheitsverglasung, gefederter Fahrer- und Beifahrersitz, motorabhängige Warmwasserheizung. Kontroll- und Bedienungselemente für den Fahrbetrieb.

Elektrische Anlage

24 Volt Gleichstrom-Anlage, 2 Batterien, elektr. Anlage entspricht EU-Norm.



Rahmen

Verwindungssteife Schweißkonstruktion, einreihige, außenverzahnte Kugeldrehverbindung um 360° unbegrenzt drehbar.

Hydrauliksystem

Diesel-hydraulisch mit 3-Kreis-Hydraulik, 1 Axialkolben-Doppelpumpe (hydraulisch verstellbar), 1 dreifach-Zahnradpumpe.

Steuerung

Zwei 4-fach Kreuzsteuerhebel, hydraulische Vorsteuerung.

Teleskopausleger

1 Grundaussleger und 3 Teleskopteile. Alle Teleskope sind hydraulisch auch mit Teillast teleskopierbar. Länge: 9.22 m bis 30.0 m

Auslegerverlängerungen*

Gitterklappspitze 9.05 m, abwinkelbar 0°/15°/30°,
Doppelklappspitze 8.7 m/15.45 m, abwinkelbar 0°/15°/30°

Wippwerk

1 Differential-Zylinder mit angebautem Senkbremsventil.

Hubwerk

Axialkolben-Konstant-Motor, Hubwerkstrommel mit eingebautem Planetengetriebe und federbelasteter Lamellenbremse mit integriertem Freilauf.

Drehwerk

Konstant-Motor, zweistufiges Planetengetriebe mit fußbetätigter Betriebsbremse und Feststellung.

Gegengewicht

7.5 t teilbar, Betätigung erfolgt aus der Krankabine, (9.6 t teilbar*).

Oberwagenkabine

Stahlblech-Ausführung mit Sicherheitsverglasung, verstellbarer hydraulisch gedämpfter Fahrersitz, motorunabhängige Warmluftheizung. Kontroll- und Bedienungselemente für den Kran- und Baustellenfahrbetrieb.

Sicherheitseinrichtungen

Sicherheitsventile gegen Rohr- und Schlauchbrüche, Lastmomentbegrenzung, Windenendschalter, Hubendschalter, Seilwindendrehmelder.



Frame

Box-type, torsion resistant, welded construction made of high tensile steel with integral outrigger housings.

Outriggers

4 point, fully hydraulic controlled from upper cab and from both sides of carrier. Outrigger spread 6.28 m (mid extension 4.70 m).

Engine

Mercedes Benz 6 cylinder (EURO 1), diesel, water-cooled engine, model OM 401 LA, rating 213 kW (290 HP) at 2100 rpm.
Torque 1180 Nm (120 kpm) at 1200 rpm.

Transmission

ZF powershift transmission with torque converter lock-up with 6 forward gears and 1 reverse gear.

Drive

6 x 4 on road/6 x 6 off road.

Axles

1st axle: driven, steered, with differential lock.
2nd axle: driven, steered, inter-axle and transverse differential lock.
3rd axle: single wheel suspension, driven, steered, differential lock.

Suspension system

Hydro-pneumatic, hydraulically lockable with levelling adjustment. Overall height adjustable +/- 100 mm.

Brake system

Service brakes: dual circuit compressed air system.
Parking brake: spring loaded type acting on 2nd and 3rd axle.
Auxiliary brake: Engine exhaust brake and constant throttle valve system, Telma brake*.

Tyres

16.00 R 25 on/off road profile.

Steering system

From carrier cab: ZF dual circuit semi-block mechanical steering of front two axles with hydraulic booster and transmission-mounted emergency pump.
From crane cab: hydro-static steering with 3 steering modes: front 2 axle steer, all wheel steer and crab steer.

Carrier cab

Two man full width cab of composite (steel sheet metal and fibre-glass) structure, with safety glass, cushioned adjustable seats, motor dependent warm-water heater. Complete controls and instrumentation for road travel.

Electrical system

24 volt DC system with 2 batteries. Lighting according to EEC regulations.



Frame

Torsion-resistant all-welded structure of high strength steel. Connected to carrier by single-row ball slewing ring with external gearing for 360° continuous rotation.

Hydraulic system

Engine driven, 3 circuit hydraulic system with one variable displacement axial piston double pump hydraulically adjustable and one fixed displacement pump.

Hydraulic controls

2 joy-stick type control levers for simultaneous crane motions, infinitely controlled.

Telescopic main boom

Four section box type construction of high tensile, fine-grained steel consisting of 1 base section and 3 telescoping sections. All sections hydraulically extendable under load. 9.22 - 30.0 m long.

Boom extensions*

Swing-around lattice boom extension 9.05 m. Offsets 0°/15°/30°. Double-folding swing-around lattice boom extension 8.7 m/15.45 m. Offsets 0°/15°/30°.

Boom hoist

One double acting hydraulic cylinder with integral holding valve.

Main winch

Axial piston fixed displacement motor with planetary reduction and spring loaded multiple disc holding brake.

Slewing gear

Constant displacement motor with planetary reduction with foot controlled service brake and parking brake. Slewing speed infinitely variable 0 - 2.0 rpm.

Counterweight

7.5 t divisible controlled from crane cab (9.6 t divisible*).

Crane cab

Spacious all-steel comfortable panoramic cab with special tinted safety glass, hydraulically cushioned and adjustable seat, independent hot-air heater. Controls and instrumentation for crane operation and on-site travelling.

Safety devices

Load moment device (LMD). Safety valves against pipe and hose rupture, holding valves on hydraulic cylinders, lower limit switch on main winch and drum turn indicator.

**Châssis**

Structure en caisson, résistante aux torsions et flexions.

Stabilisation

Calage à 4 points, complètement hydraulique. Commande des stabilisateurs à partir de la cabine du grutier et latéralement à gauche et à droite du châssis, y compris demi-calage. Largeur de calage 6.28 m et 4.70 m.

Moteur

Mercedes-Benz, 6 cylindres, OM 401 LA (EURO 1), refroidi par eau, 213 kW (290 CV) à 2100 tr./min., couple: 1180 Nm (120 kpm) à 1200 tr./min.

Boîte de vitesses

Boîte powershift ZF, avec convertisseur de couple et embrayage "Lock-up" (à partir de 1^{ère} vitesse) avec 6 marches avant et 1 arrière.

Entraînement

6 x 4 pour marche sur route
6 x 6 pour marche tout-terrain

Essieux

1^{er} essieu: moto-directeur, blocage de différentiel entre-roues.
2^{ème} essieu: moto-directeur, blocage de différentiel entre-ponts et entre-roues.
3^{ème} essieu: suspension de roues indépendantes, moto-directeur, blocage de différentiel.

Suspension des essieux

Hydro-pneumatique, blocable électro-hydrauliquement avec réglage de niveau. Course de compression/rebondissement +/- 100 mm.

Freins

Frein de service: système à air comprimé, à double circuit.
Frein de stationnement: avec accumulateurs à ressort agissant sur le 2^{ème} et 3^{ème} essieu.
Frein continu: frein sur échappement et étrangleur. Frein Telma*

Pneus

16.00 R 25 en profil pour route et terrain.

Direction

Direction semi-bloc à double circuit, agissant sur le premier et deuxième essieu, à assistance hydraulique, avec pompe de secours de direction et marche en crabe. La direction de tous les essieux est possible.

Cabine du conducteur

Cabine bi-place, construction en matière combinée acier/synthétique (GFK). Vitrage en verre de sécurité, siège du conducteur et du co-pilote à ressort et amorti hydrauliquement. Chauffage à eau chaude alimenté par le moteur. Organes de commande et de contrôle pour conduire la grue.

Équipement électrique

Système à 24 V C.C., 2 batteries, conforme à la norme CE.

**Plate forme**

Construction mécano-soudée résistante à la torsion. Couronne d'orientation à billes à une rangée, à denture extérieure; permettant une rotation illimitée sur 360°.

Système hydraulique

Système diesel-hydraulique à 3 circuits, 1 pompe doublée à piston axial (à réglage hydraulique), 1 pompe à engrenages triple.

Commande

Deux leviers de commande orientables en 4 sens, assistés hydrauliquement.

Flèche télescopique

1 flèche de base et 3 éléments télescopiques, tous hydrauliquement télescopables aussi sous charge partielle. Longueur de flèche 9.22 m à 30.0 m.

Fléchettes*

Construction en treillis, longueur 9.05 m, rabattable latéralement et inclinable à 0°/15°/30°. Fléchette double en construction treillis, longueur 8.70 m/15.45 m, rabattable latéralement et inclinable à 0°/15°/30°.

Mécanisme de relevage

1 vérin différentiel muni de clapet de freinage de descente.

Mécanisme de levage

Moteur hydraulique, tambour de levage avec boîte planétaire incorporée, frein d'arrêt à disques multiples à ressort, libéré lors du levage.

Mécanisme de rotation

Moteur hydraulique avec entraînement planétaire à 2 gammes. Frein de service actionné par l'intermédiaire d'une pédale et arrêt.

Contrepoids

7.5 t, divisible, commandé à partir de la cabine du grutier (9.6 t divisible sur commandé*).

Cabine de conduite

En acier avec vitrage de sécurité, siège suspendu sur ressort, amorti hydrauliquement et réglable, chauffage à air chaud indépendant du moteur, avec éléments de commande et de contrôle pour manoeuvrer la grue et pour la conduire sur chantier.

Dispositifs de sécurité

Clapets anti-retour contre l'éventuelle rupture des conduites ou flexibles, interrupteur de fin de course du treuil pour câble de levage sur le tambour, limiteur de couple de charge, interrupteur de fin de course de levage.



Chasis

Construcción de acero soldado resistente a la torsión y a la flexión.

Estabilizadores

Estabilizadores hidráulicos de 4 puntos controlados desde la superestructura y desde ambos lados del chasis, con posibilidad de trabajar con extensión parcial. Extensión de los estabilizadores: 6.28 m y 4.70 m.

Motor

Mercedes Benz OM 401 LA (EURO 1), 6 cilindros, refrigerado por agua, 213 kW (290 HP) a 2100 rpm. Par 1180 Nm (120 kpm) a 1200 rpm.

Transmisión

Transmisión powershift con convertidor de par con bloqueo, 6 velocidades de avance y 1 de marcha atrás.

Tracción

6 x 4 en carretera / 6 x 6 fuera de carretera.

Ejes

- 1^{er} eje: de dirección, accionado con cubos planetarios externos, bloqueo diferencial.
- 2^o eje: de dirección, accionado con cubos planetarios externos, bloqueo diferencial entre ejes y transversal.
- 3^{er} eje: suspensión de ruedas independiente, de dirección, accionado, bloqueo diferencial.

Sistema de suspensión

Hidroneumático, con bloqueo hidráulico y ajuste de nivelación. Altura total regulable \pm 100 mm.

Sistemas de frenos

Freno de servicio: sistema de freno de aire comprimido.
Freno de estacionamiento con doble circuito: acumuladores de aire en los ejes 2^o y 3^o.
Freno auxiliar: Freno de escape del motor y sistema de válvula de estrangulación constante, freno Telma*.

Neumáticos

16.00 R 25 con dibujo para carretera y fuera de ella.

Sistema de dirección

Dirección hidráulica con semibloqueo de doble circuito, actuando sobre los ejes 1^o y 2^o, dirección individual en velocidades bajas para el 3^{er} eje, cilindros de dirección en los ejes de dirección, bomba de emergencia. Conducción desde la superestructura por medio de hidro-dirección individual con control eléctrico, dirección de cangrejo.

Cabina del chasis portante

Montada en el lado izquierdo, con diseño panorámico para dos hombres, con lunas de seguridad y sillones regulables amortiguados hidráulicamente, y controles e instrumentos colocados ergonómicamente, con calentador de agua caliente dependiente del motor.

Sistema eléctrico

Sistema a 24 V c.c. con 2 baterías, de acuerdo con las normas CEE.



Superestructura

Estructura de acero toda soldada, resistente a la torsión, con corona de giro de una fila de bolas, con engranado externo para rotación continua de 360°.

Sistema hidráulico

Sistema hidráulico de 3 circuitos, accionado por el motor, con una bomba doble de pistones axiales de caudal variable y una bomba de caudal fijo.

Controles

2 palancas de control infinito de tipo universal (joy-stick) para movimientos simultáneos de la grúa.

Pluma telescópica

Una base de pluma y tres tramos telescópicos. Todos los tramos se extienden hidráulicamente bajo carga, longitud de 9.22 m a 30.0 m.

Prolongaciones de la pluma*

Prolongación de la pluma, de celosía, abatible lateralmente, de 9.05 m. Con angulación de 0° / 15° / 30°.

Prolongación de la pluma, de celosía, abatible lateralmente, de doble plegado, de 8.7 m - 15.45 m. Con angulación de 0° / 15° / 30°.

Sistema de elevación de la pluma

Un cilindro hidráulico de doble efecto con válvula de retención integrada.

Cabrestante principal

Motor de pistones axiales de desplazamiento fijo con reducción planetaria integrados y freno de retención multidisco cargado por resortes.

Sistema de giro

Motor hidráulico con reducción planetaria con freno de servicio controlado con el pie y freno de retención automático.

Contrapeso

De 7.5 ton divisible controlado desde la cabina de la grúa. (9.6 ton divisible*).

Cabina de la grúa

De diseño panorámico, montada en el lado izquierdo. Espaciosa, con estructura totalmente de acero y con lunas de seguridad especiales, con sillón regulable amortiguado hidráulicamente y calentador por aire caliente independiente. Completa con controles e instrumentos para la operación de la grúa y para el desplazamiento en solar.

Dispositivos de seguridad

Válvulas de seguridad contra rotura de tuberías y latiguillos e interruptor de límite del cabrestante principal. Dispositivo electrónico de momento de carga y dispositivo interruptor de final de carrera del cabrestante. Indicador de vueltas del tambor.

Hakenhöhen / Kopfhöhen
 Hook height / Tip height
 Hauteurs sous crochet / Hauteurs tête de flèche
 Altura del gancho / Altura de la punta

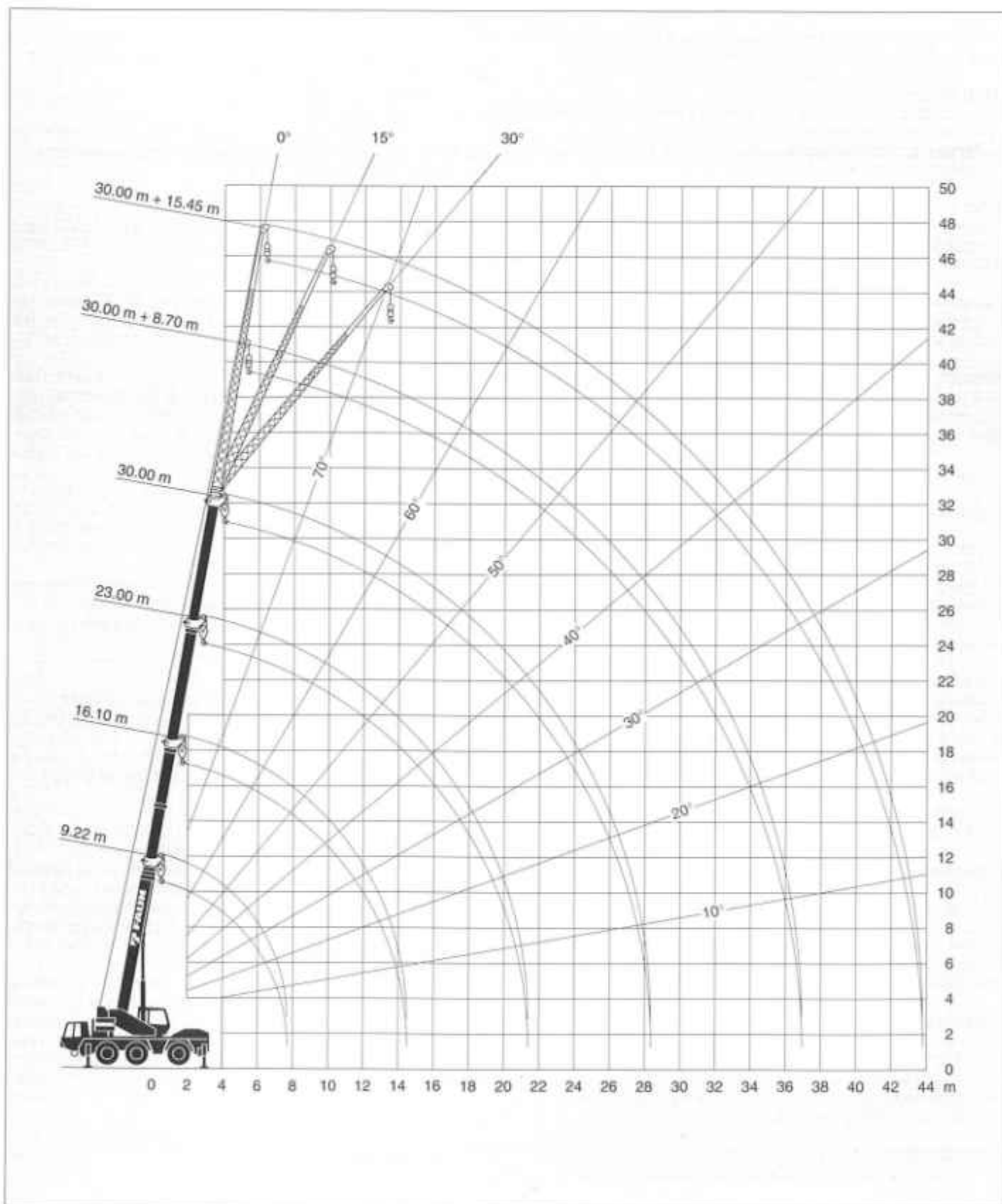

24

	D	→	00 49	
A	B	CH	DK	F
GB	I	N	NL	P
E	07	49	S	00 949

	(0) 91 23 95 50	
	(0) 17 18 11 43 24	
	(0) 91 23 18 51 55	
	(0) 91 23 18 52 19	
	(0) 91 23 30 85	
	http://www.tadanofaun.de	
	http://www.faun.de	
	e-mail: info@tadanofaun.de	
		→ 