

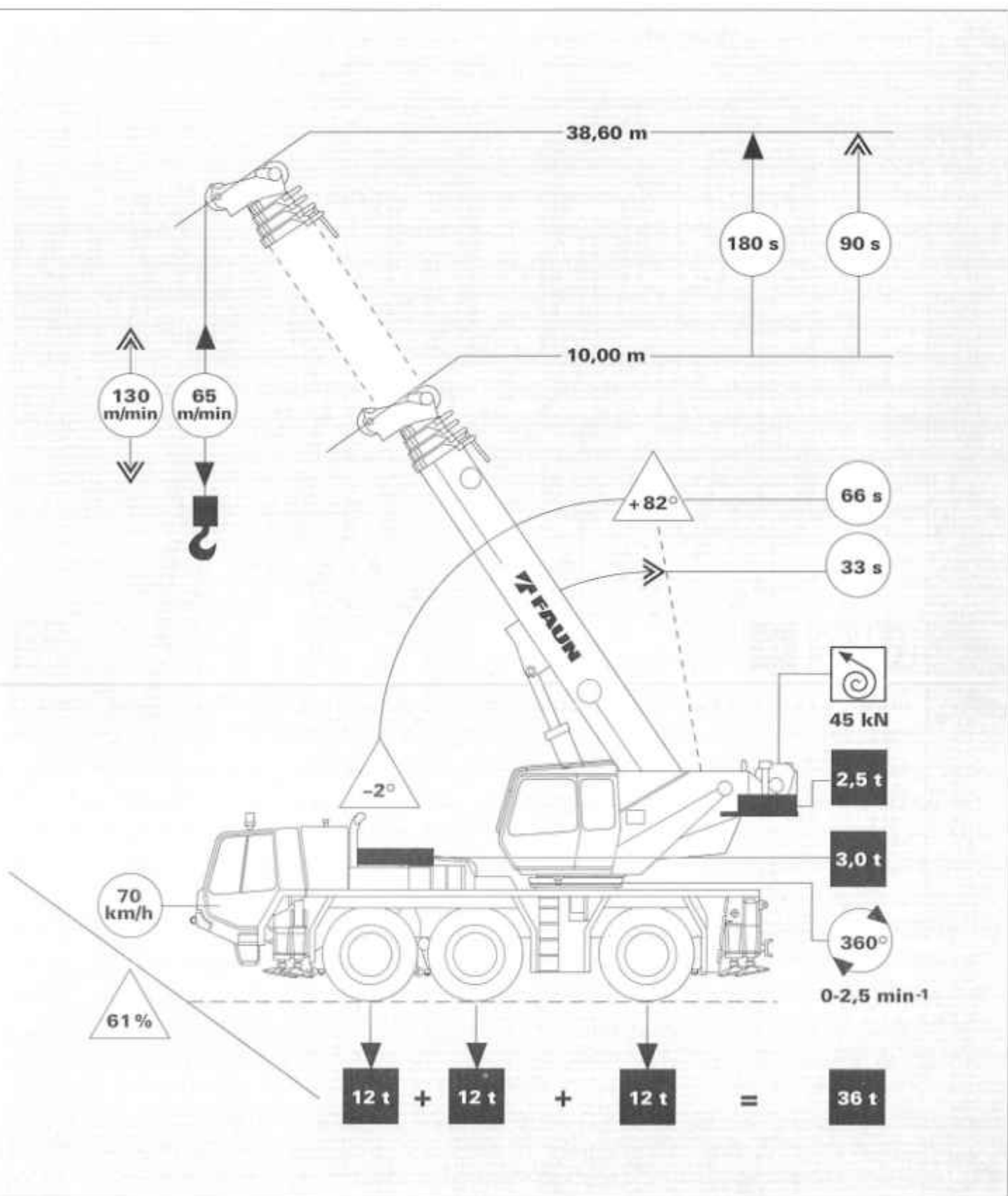

ATF 50-3

5-Section





Tragfähigkeiten am Teleskopausleger
Lifting capacities on telescopic boom
Capacités de levage à la flèche télescopique



DIN

↘ m	10.0 m	17.2 m	17.2 m	17.2 m	24.3 m	24.3 m	24.3 m	31.5 m	31.5 m	35.0 m	38.6 m
2.7	50.0										
3.0	47.1										
3.5	43.8	20.0	30.0	13.0							
4.0	39.5	20.0	29.0	13.0							
4.5	36.5	20.0	27.5	13.0							
5.0	32.5	20.0	26.2	13.0	13.0	17.0	11.8				
6.0	27.0	20.0	22.6	13.0	13.0	17.0	11.8	13.0	9.5		
7.0	21.9	20.0	19.8	13.0	13.0	15.8	11.8	13.0	9.2		
8.0		19.4	17.5	13.0	13.0	14.5	11.8	13.0	8.8	9.0	7.0
9.0		15.7	15.1	13.0	13.0	13.3	11.4	12.0	8.5	8.8	7.0
10.0		13.2	12.6	13.0	13.0	12.0	11.0	11.0	8.1	8.5	7.0
11.0		11.2	10.6	12.5	12.2	10.9	10.5	10.1	7.7	8.3	7.0
12.0		9.6	9.1	10.9	10.6	9.4	10.1	9.2	7.4	8.1	7.0
14.0		7.4	6.9	8.6	8.2	7.1	8.8	7.8	6.7	7.6	6.5
16.0					6.4	5.3	7.0	6.0	5.8	6.3	6.1
18.0					5.1	4.1	5.7	4.8	5.1	5.0	5.3
20.0					4.2	3.2	4.8	3.8	4.5	4.1	4.3
22.0					3.5	2.5	4.0	3.1	4.0	3.3	3.5
24.0								2.5	3.6	2.7	2.9
26.0								1.9	2.8	2.1	2.4
28.0								1.5	2.4	1.7	1.9
30.0										1.3	1.5
32.0										1.0	1.2
34.0											0.9
36.0											0.7
	I 0	50	100	0	50	100	0	100	0	100	100
	II 0	50	0	33	50	100	66	100	100	100	100
	III 0	0	0	33	50	0	66	50	100	75	100
	IV 0	0	0	33	50	0	66	50	100	75	100



85%

↘ m	10.0 m	17.2 m	17.2 m	17.2 m	24.3 m	24.3 m	24.3 m	31.5 m	31.5 m	35.0 m	38.6 m
2.7	55.0										
3.0	50.4										
3.5	46.7	22.0	32.0	14.0							
4.0	42.3	22.0	31.2	14.0							
4.5	38.0	22.0	29.6	14.0							
5.0	34.8	22.0	28.2	14.0	14.0	18.5	13.0				
6.0	29.0	22.0	24.4	14.0	14.0	18.5	13.0	14.0	10.5		
7.0	23.6	22.0	21.4	14.0	14.0	17.2	13.0	14.0	10.0		
8.0		21.0	19.0	14.0	14.0	15.8	13.0	14.0	9.6	10.0	7.7
9.0		17.0	16.4	14.0	14.0	14.5	12.4	13.1	9.3	9.7	7.7
10.0		14.4	13.7	14.0	14.0	13.1	11.9	12.0	8.9	9.3	7.7
11.0		12.2	11.6	13.5	13.3	12.0	11.4	11.1	8.4	9.1	7.7
12.0		10.5	10.1	11.9	11.6	10.4	11.0	10.1	8.1	8.9	7.7
14.0		8.2	7.7	9.4	9.0	7.9	9.6	8.6	7.4	8.4	7.2
16.0					7.1	6.0	7.7	6.7	6.4	7.0	6.8
18.0					5.7	4.7	6.3	5.4	5.7	5.6	5.9
20.0					4.8	3.7	5.4	4.3	5.0	4.7	4.9
22.0					4.0	2.9	4.5	3.5	4.5	3.8	4.0
24.0								2.9	4.1	3.1	3.3
26.0								2.2	3.2	2.5	2.8
28.0								1.7	2.7	1.9	2.2
30.0										1.5	1.8
32.0										1.2	1.4
34.0											1.1
36.0											0.8
	I 0	50	100	0	50	100	0	100	0	100	100
	II 0	50	0	33	50	100	66	100	100	100	100
	III 0	0	0	33	50	0	66	50	100	75	100
	IV 0	0	0	33	50	0	66	50	100	75	100



DIN

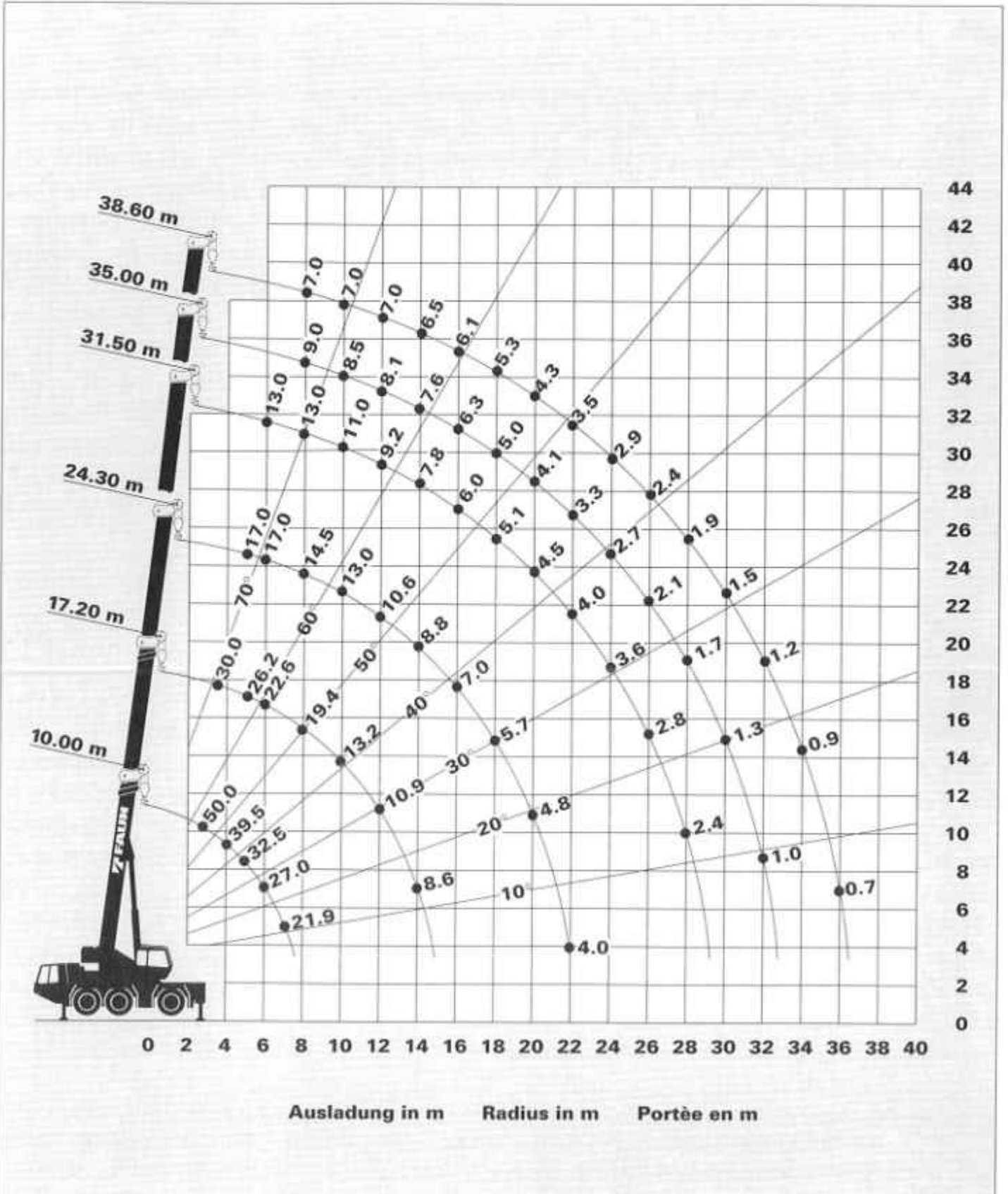

Tragfähigkeiten am Teleskopausleger
Lifting capacities on telescopic boom
Capacités de levage à la flèche télescopique



5,5t

DIN

→ m	10.0 m	17.2 m	17.2 m	17.2 m	24.3 m	24.3 m	24.3 m	31.5 m	31.5 m	35.0 m	38.6 m
2.7	50.0										
3.0	45.0										
3.5	40.5	20.0	30.0	13.0							
4.0	37.0	20.0	29.0	13.0							
4.5	34.5	20.0	27.5	13.0							
5.0	31.8	20.0	26.2	13.0	13.0	17.0	11.8				
6.0	26.4	20.0	22.6	13.0	13.0	17.0	11.8	13.0	9.5		
7.0	21.0	20.0	19.4	13.0	13.0	15.8	11.8	13.0	9.2		
8.0		15.7	15.0	13.0	13.0	14.5	11.8	13.0	8.8	9.0	7.0
9.0		12.7	12.1	13.0	13.0	12.5	11.4	12.0	8.5	8.8	7.0
10.0		10.6	10.0	12.0	11.6	10.3	11.0	11.0	8.1	8.5	7.0
11.0		8.8	8.2	10.2	9.9	8.6	10.5	9.5	7.7	8.3	7.0
12.0		7.4	6.8	8.8	8.4	7.2	9.2	8.0	7.4	8.1	7.0
14.0		5.4	4.9	6.7	6.3	5.2	7.0	6.0	6.7	6.0	6.5
16.0					4.9	3.8	5.5	4.4	5.6	4.6	4.8
18.0					3.7	2.7	4.3	3.4	4.5	3.6	3.8
20.0					2.9	1.9	3.5	2.6	3.6	2.8	3.0
22.0					2.3	1.3	2.9	2.0	3.0	2.2	2.4
24.0								1.4	2.5	1.7	1.9
26.0								1.0	2.0	1.2	1.4
28.0								0.7	1.6	0.8	1.0
30.0										0.5	0.7
32.0											
34.0											
36.0											

	I	0	50	100	0	50	100	0	100	0	100	100
	II	0	50	0	33	50	100	66	100	100	100	100
	III	0	0	0	33	50	0	66	50	100	75	100
	IV	0	0	0	33	50	0	66	50	100	75	100



5,5t

85%

→ m	10.0 m	17.2 m	17.2 m	17.2 m	24.3 m	24.3 m	24.3 m	31.5 m	31.5 m	35.0 m	38.6 m
2.7	55.0										
3.0	48.1										
3.5	43.4										
4.0	39.6	22.0	32.0	14.0							
4.5	37.0	22.0	29.6	14.0							
5.0	34.1	22.0	28.2	14.0	14.0	18.5	13.0				
6.0	28.4	22.0	24.4	14.0	14.0	18.5	13.0	14.0	10.5		
7.0	22.6	22.0	21.0	14.0	14.0	17.2	13.0	14.0	10.0		
8.0		17.0	16.3	14.0	14.0	15.8	13.0	14.0	9.6	10.0	7.7
9.0		13.9	13.3	14.0	14.0	13.7	12.4	13.1	9.3	9.7	7.7
10.0		11.6	11.0	13.0	12.6	11.3	11.9	12.0	8.9	9.3	7.7
11.0		9.7	9.1	11.1	10.8	9.5	11.4	10.4	8.4	9.1	7.7
12.0		8.2	7.6	9.6	9.2	8.0	10.0	8.9	8.1	8.9	7.7
14.0		6.1	5.6	7.4	7.0	5.9	7.7	6.7	7.4	6.7	7.2
16.0					5.5	4.4	6.1	5.0	6.2	5.2	5.4
18.0					4.2	3.1	4.8	3.9	5.0	4.1	4.3
20.0					3.3	2.2	4.0	3.0	4.1	3.2	3.5
22.0					2.6	1.5	3.3	2.3	3.4	2.5	2.8
24.0								1.6	2.9	2.0	2.2
26.0								1.2	2.3	1.4	1.6
28.0								0.8	1.9	1.0	1.2
30.0										0.6	0.8
32.0											0.5
34.0											
36.0											





	I	0	50	100	0	50	100	0	100	0	100	100
	II	0	50	0	33	50	100	66	100	100	100	100
	III	0	0	0	33	50	0	66	50	100	75	100
	IV	0	0	0	33	50	0	66	50	100	75	100

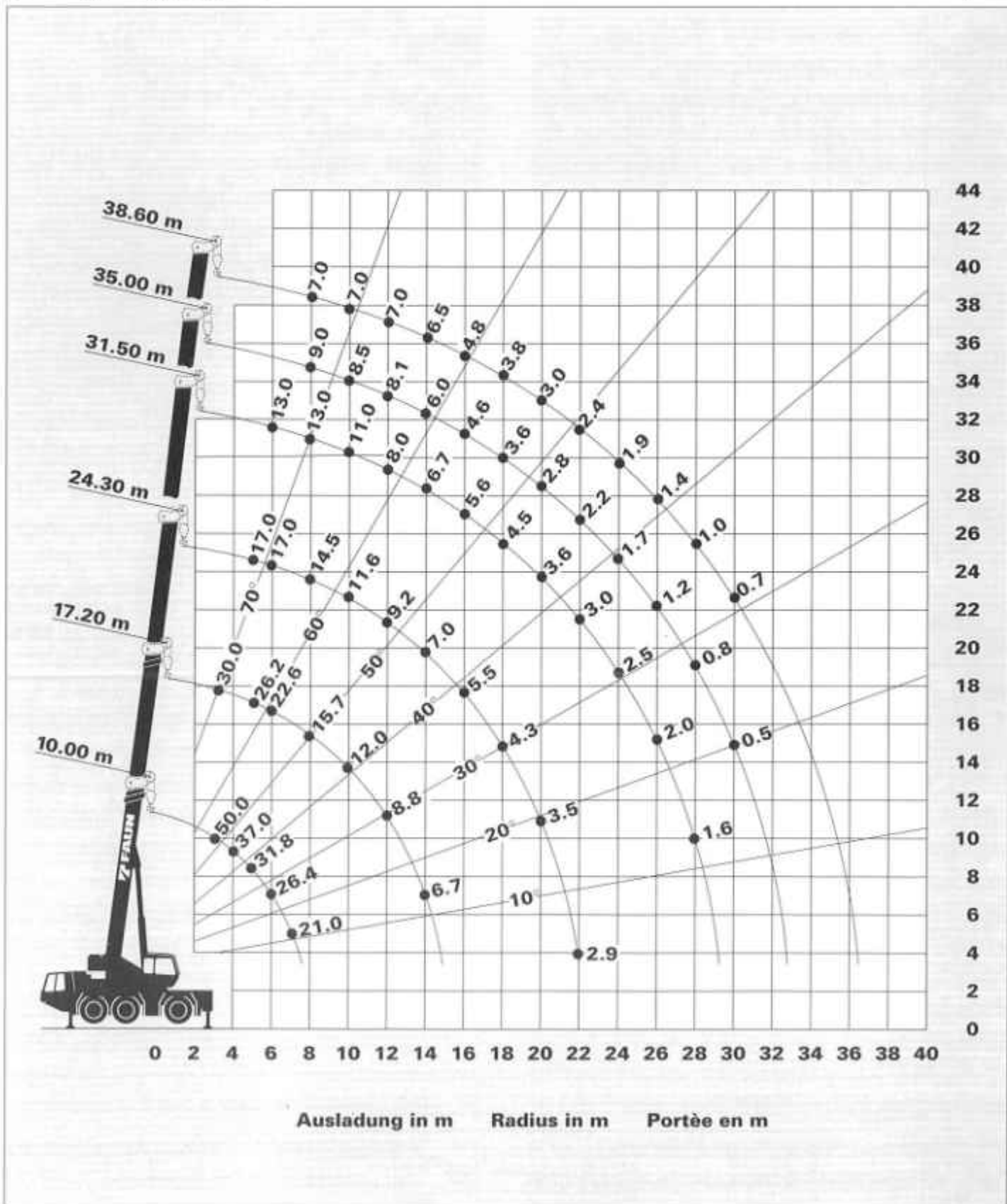









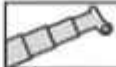

DIN







Tragfähigkeiten am Teleskopausleger
Lifting capacities on telescopic boom
Capacités de levage à la flèche télescopique

   10t* DIN			
 m	10.0 m	17.2 m	
3.0	10.8	11.4	
3.5	9.6	10.2	
4.0	8.6	9.2	
4.5	7.7	8.3	
5.0	7.0	7.6	
6.0	5.7	6.3	
7.0	4.8	5.4	
8.0		4.6	
9.0		3.9	
10.0		3.3	
11.0		2.9	
12.0		2.5	
14.0		1.9	
 %	I 0	II 0	III 33
	II 0	III 33	IV 33
	III 0	IV 33	
	IV 0		

   5,5t DIN			
 m	10.0 m	17.2 m	
3.0	10.4	11.1	
3.5	9.2	9.9	
4.0	8.2	8.9	
4.5	7.4	8.1	
5.0	6.7	7.3	
6.0	5.5	6.1	
7.0	4.5	5.2	
8.0		4.4	
9.0		3.8	
10.0		3.3	
11.0		2.8	
12.0		2.4	
14.0		1.8	
 %	I 0	II 0	III 33
	II 0	III 33	IV 33
	III 0	IV 33	
	IV 0		

   10t* 85%			
 m	10.0 m	17.2 m	
3.0	12.0	12.5	
3.5	10.5	11.1	
4.0	9.5	10.0	
4.5	8.5	9.1	
5.0	7.8	8.3	
6.0	6.4	7.0	
7.0	5.5	6.0	
8.0		5.2	
9.0		4.4	
10.0		3.8	
11.0		3.3	
12.0		2.9	
14.0		2.2	
 %	I 0	II 33	III 33
	II 0	III 33	IV 33
	III 0	IV 33	
	IV 0		

   5,5t 85%			
 m	10.0 m	17.2 m	
3.0	11.4	12.0	
3.5	10.1	10.8	
4.0	9.0	9.7	
4.5	8.2	8.9	
5.0	7.4	8.0	
6.0	6.2	6.7	
7.0	5.1	5.8	
8.0		4.9	
9.0		4.3	
10.0		3.8	
11.0		3.2	
12.0		2.8	
14.0		2.1	
 %	I 0	II 33	III 33
	II 0	III 33	IV 33
	III 0	IV 33	
	IV 0		



DIN

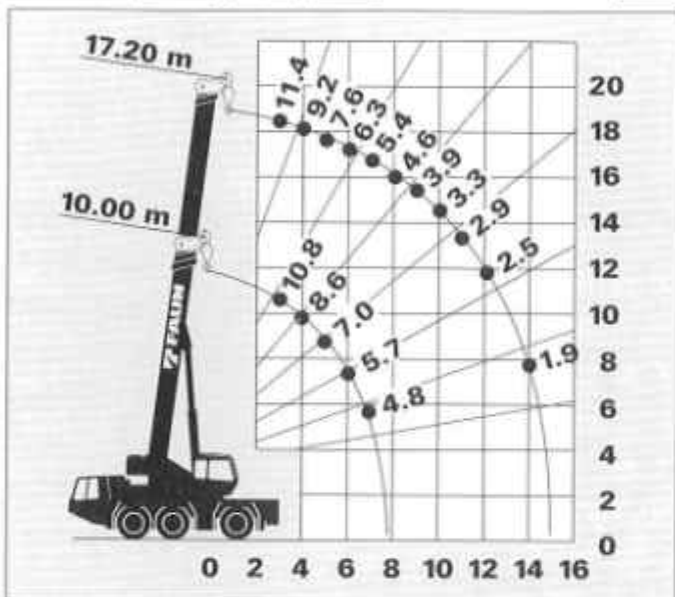

Ausladung in m Radius in m Portée en m



DIN

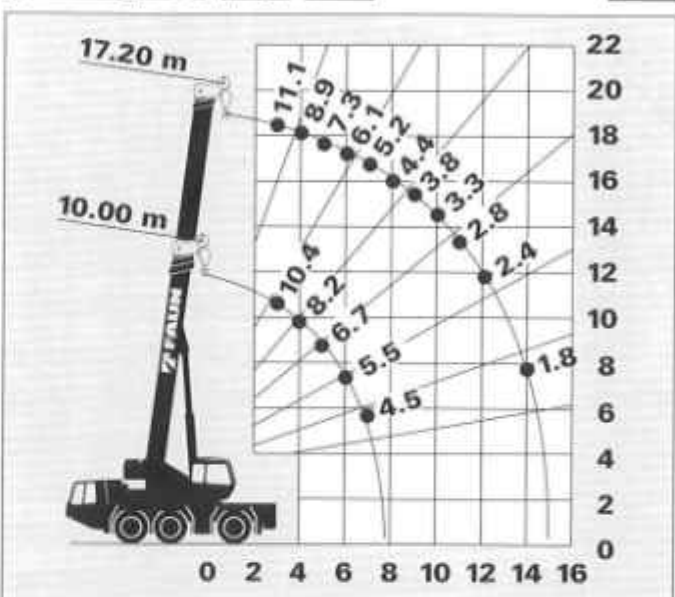

Ausladung in m Radius in m Portée en m

Anmerkungen zu den Traglasttabellen

- Die angegebenen Traglasten überschreiten nicht 75% bzw. 85% der Kipplast.
- Die Traglasten entsprechen DIN 15019 Teil 2 und DIN 15018 Teil 3.
- Maximal zulässige Windgeschwindigkeit 15 m/sec.
- Die Traglasten sind in Tonnen angegeben.
- Das Gewicht des Lasthakens und der Schlingen usw. ist von den Traglasten abzuziehen.
- Der Radius ist der Abstand von Mitte Drehkranz bis Mitte freihängender, nicht schwingender Last.
- Die Traglasten für den Teleskopausleger gelten nur bei demontierter Spitze. Obige Angaben dienen nur zur Information. Die Bedienungsanleitungen müssen zu Rate gezogen werden, bevor die Maschine in Betrieb genommen wird. Alle hier gemachten Angaben beziehen sich auf die Standard-Ausführung. Jegliche Ausrüstungsveränderungen können die angegebenen Werte beeinflussen. **Änderungen vorbehalten.**

Remarks relating to rating charts

- The lifting capacities shown do not exceed 75% or 85% of the tipping load.
- The lifting capacities shown comply with DIN 15019 (Part 2) and DIN 15018 (Part 3).
- Maximum allowable wind speed by crane operation is 15 m/sec.
- The lifting capacities shown are in metric tons.
- The weight of load handling devices such as hook blocks, slings, etc., shall be considered part of the load.
- Operating radius is the horizontal distance from the vertical axis of rotation of the upper superstructure to the centre of the load handling device with the load applied.
- The telescopic boom capacities shown apply to a machine without any boom extensions being on the machine (either stored or mounted). The above remarks are for basic information only and the operator's manual must be consulted before operating this machine. All data and performances refer to a standard machine. The additional of optional or other equipment may affect the performance of the machine. **The information contained in this bulletin is subject to change without prior notice.**

Remarques relatives aux tableaux des charges

- Les forces de levage indiquées ne dépassent pas 75% ou 85% de la charge de basculement.
- Les forces de levage conformes à la norme DIN 15019.2 et DIN 15018.3.
- La grue peut travailler jusqu'à une vitesse du vent de 15 m/s.
- Les forces de levage sont données en tonnes.
- Le poids du crochet-moufle et de tous les accessoires d'elingage font partie de la charge et sont à déduire des charges indiquées.
- Les portées sont calculées à partir de l'axe de rotation.
- Les forces de levage indiquées pour la flèche télescopique s'entendent flèche déposée. Les données ci-dessus servent à titre d'information. Avant mise en marche de la grue il est conseillé d'étudier les manuels d'opération. Toutes données ci-dessus se réfèrent à la machine de base. Tout changement de l'équipement de la grue peut influencer les valeurs indiquées. **Sous réserve de modification.**

Tragfähigkeiten an der Spitze*
 Lifting capacities on boom extension*
 Capacités de levage à la rallonge de flèche*

DIN

→m	35.0 m + 9.0 m			38.6 m + 9.0 m			38.6 m + 16.0 m		
	5°	17°	30°	5°	17°	30°	5°	17°	30°
10.0	4.80			3.80					
11.0	4.80			3.80					
12.0	4.80			3.80					
14.0	4.60			3.80	3.40		2.20		
16.0	4.40			3.68	3.26	2.69	2.20	1.80	
18.0	4.20	3.15	3.00	3.55	3.12	2.57	2.13	1.73	1.30
20.0	3.75	2.92	2.37	3.43	2.98	2.46	2.06	1.66	1.27
22.0	3.39	2.72	2.25	3.30	2.84	2.34	1.99	1.59	1.23
24.0	2.70	2.53	2.14	2.80	2.70	2.23	1.92	1.51	1.20
26.0	2.20	2.35	2.04	2.25	2.40	2.14	1.85	1.44	1.17
28.0	1.75	1.85	1.96	1.85	1.95	2.05	1.70	1.37	1.13
30.0	1.40	1.50	1.60	1.45	1.60	1.70	1.57	1.30	1.10
32.0	1.05	1.15	1.20	1.15	1.20	1.30	1.46	1.23	1.05
34.0	0.75	0.85	0.90	0.85	0.95	1.00	1.30	1.17	1.01
36.0	0.50	0.55	0.60	0.60	0.65	0.70	1.05	1.11	0.98
38.0	0.30	0.30	0.35	0.35	0.40	0.45	0.80	0.95	0.94
40.0							0.60	0.70	0.80
42.0							0.40	0.50	0.60
44.0								0.30	0.40
46.0									
48.0									
50.0									

	I	100		100		100
	II	100		100		100
	III	75		100		100
	IV	75		100		100



85%

→m	35.0 m + 9.0 m			38.6 m + 9.0 m			38.6 m + 16.0 m		
	5°	17°	30°	5°	17°	30°	5°	17°	30°
10.0	5.50			4.30					
11.0	5.50			4.30					
12.0	5.50			4.30	3.90		2.50		
14.0	5.20	4.50	3.45	4.30	3.90	3.20	2.50	2.05	
16.0	5.00	3.96	3.06	4.23	3.75	3.10	2.50	2.05	1.50
18.0	4.79	3.62	2.89	4.08	3.59	2.96	2.45	2.00	1.50
20.0	4.31	3.36	2.73	3.95	3.43	2.83	2.37	1.91	1.46
22.0	3.89	3.13	2.59	3.80	3.27	2.69	2.29	1.83	1.42
24.0	3.10	2.91	2.46	3.20	3.10	2.57	2.21	1.74	1.38
26.0	2.55	2.70	2.35	2.60	2.75	2.46	2.13	1.66	1.35
28.0	2.00	2.15	2.25	2.10	2.25	2.36	1.96	1.58	1.30
30.0	1.60	1.75	1.85	1.65	1.85	1.95	1.81	1.50	1.27
32.0	1.20	1.35	1.40	1.30	1.40	1.50	1.68	1.43	1.21
34.0	0.85	1.00	1.05	0.95	1.10	1.20	1.50	1.35	1.16
36.0	0.60	0.70	0.70	0.70	0.75	0.80	1.20	1.28	1.13
38.0	0.40	0.40	0.40	0.40	0.50	0.50	0.95	1.10	1.08
40.0							0.70	0.80	0.90
42.0							0.50	0.60	0.70
44.0								0.40	0.50
46.0									
48.0									
50.0									

	I	100		100		100
	II	100		100		100
	III	75		100		100
	IV	75		100		100

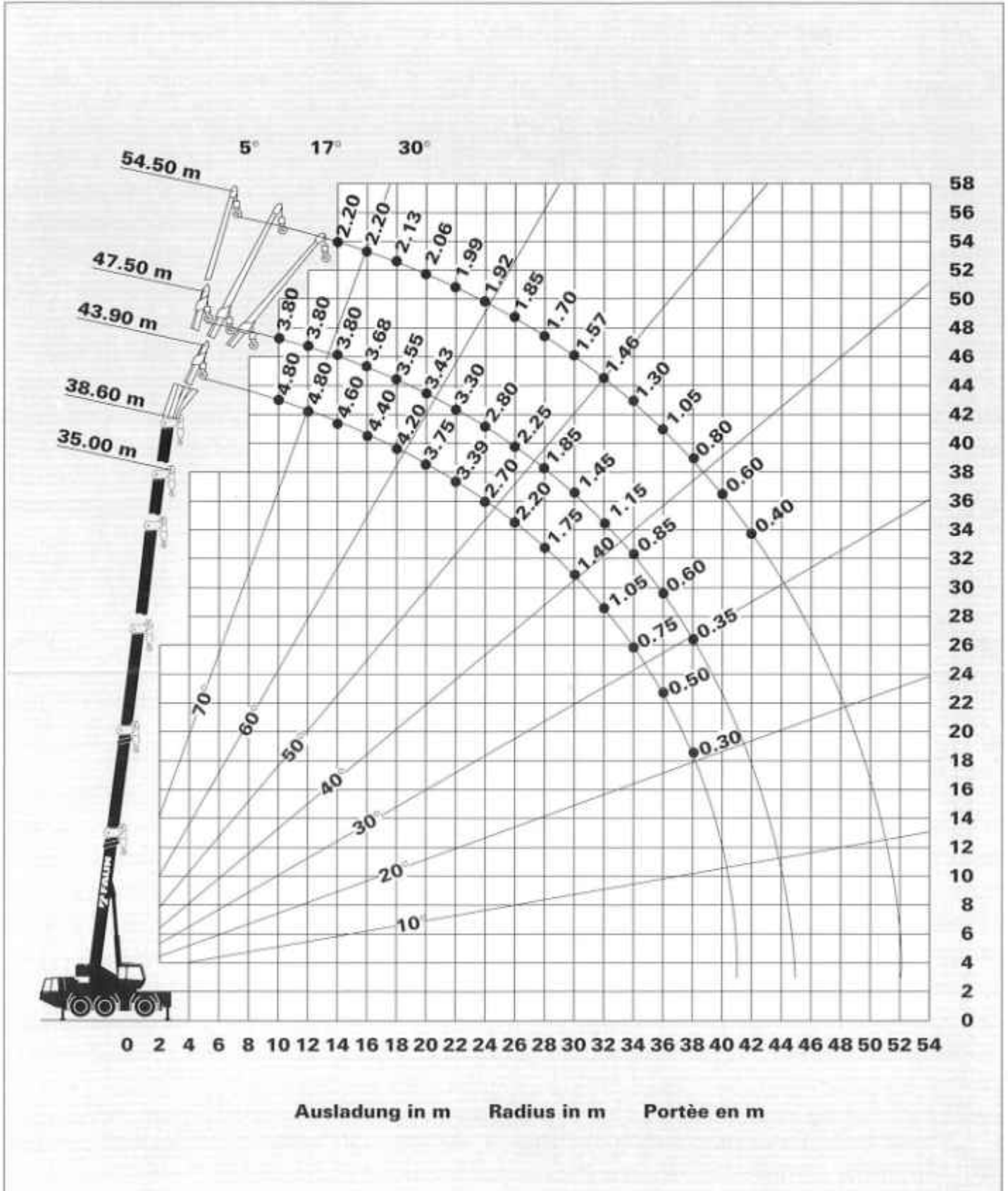

DIN



Tragfähigkeiten an der Spitze*
 Lifting capacities on boom extension*
 Capacités de levage à la rallonge de flèche*



DIN

→ m	35.0 m + 9.0 m			38.6 m + 9.0 m			38.6 m + 16.0 m		
	5°	17°	30°	5°	17°	30°	5°	17°	30°
10.0	4.80			3.80					
11.0	4.80			3.80					
12.0	4.80			3.80					
14.0	4.60			3.80					
16.0	4.39	4.00	3.00	3.68	3.40		2.20		
18.0	3.75	3.75	2.83	3.55	3.40	2.80	2.20	1.80	
20.0	2.90	3.45	2.66	3.00	3.12	2.69	2.20	1.80	1.30
22.0	2.25	3.15	2.51	2.98	2.98	2.57	2.06	1.73	1.30
24.0	1.75	2.92	2.37	2.35	2.46	2.34	1.99	1.66	1.27
26.0	1.30	2.45	2.25	2.00	2.34	2.15	1.92	1.59	1.23
28.0	0.95	2.05	2.05	1.80	2.15	1.99	1.85	1.51	1.20
30.0	0.60	1.45	1.60	1.40	1.70	1.92	1.85	1.44	1.17
32.0	0.30	1.05	1.20	1.00	1.25	1.70	1.50	1.37	1.13
34.0		0.70	0.80	0.65	0.80	1.25	1.15	1.30	1.10
36.0		0.40	0.50	0.40	0.50	0.90	0.85	1.05	1.05
38.0						0.60	0.60	0.80	0.95
40.0						0.30	0.40	0.55	0.70
42.0								0.30	0.45
44.0									
46.0									
48.0									
50.0									
%	I	100		100			100		
	II	100		100			100		
	III	75		100			100		
	IV	75		100			100		



85%

→ m	35.0 m + 9.0 m			38.6 m + 9.0 m			38.6 m + 16.0 m		
	5°	17°	30°	5°	17°	30°	5°	17°	30°
10.0	5.50			4.30					
11.0	5.50			4.30					
12.0	5.50			4.30					
14.0	5.20			4.30					
16.0	5.00	4.50	3.45	4.30	3.90		2.50		
18.0	4.30	4.30	3.25	4.23	3.90	3.20	2.50	2.05	
20.0	3.35	3.96	3.06	4.08	3.75	3.10	2.50	2.05	1.50
22.0	2.60	3.62	2.89	3.45	3.59	2.96	2.45	2.00	1.50
24.0	2.00	3.36	2.73	2.70	3.43	2.83	2.37	1.91	1.46
26.0	1.50	2.80	2.59	2.70	3.30	2.69	2.29	1.83	1.42
28.0	1.10	2.20	2.35	2.10	2.69	2.50	2.21	1.74	1.38
30.0	0.70	1.70	1.85	1.60	2.30	2.50	2.21	1.74	1.38
32.0	0.40	1.35	1.35	1.20	1.80	1.95	2.13	1.66	1.35
34.0		1.20	1.35	0.75	1.35	1.45	1.75	1.58	1.30
36.0		0.80	0.90	0.50	0.90	1.05	1.35	1.50	1.27
38.0		0.50	0.60	0.50	0.60	0.70	1.00	1.20	1.21
40.0						0.40	0.70	0.90	1.10
42.0							0.50	0.65	0.80
44.0								0.40	0.50
46.0									
48.0									
50.0									
%	I	100		100			100		
	II	100		100			100		
	III	75		100			100		
	IV	75		100			100		

Hubhöhen
Lifting heights
Hauteurs de levage



DIN

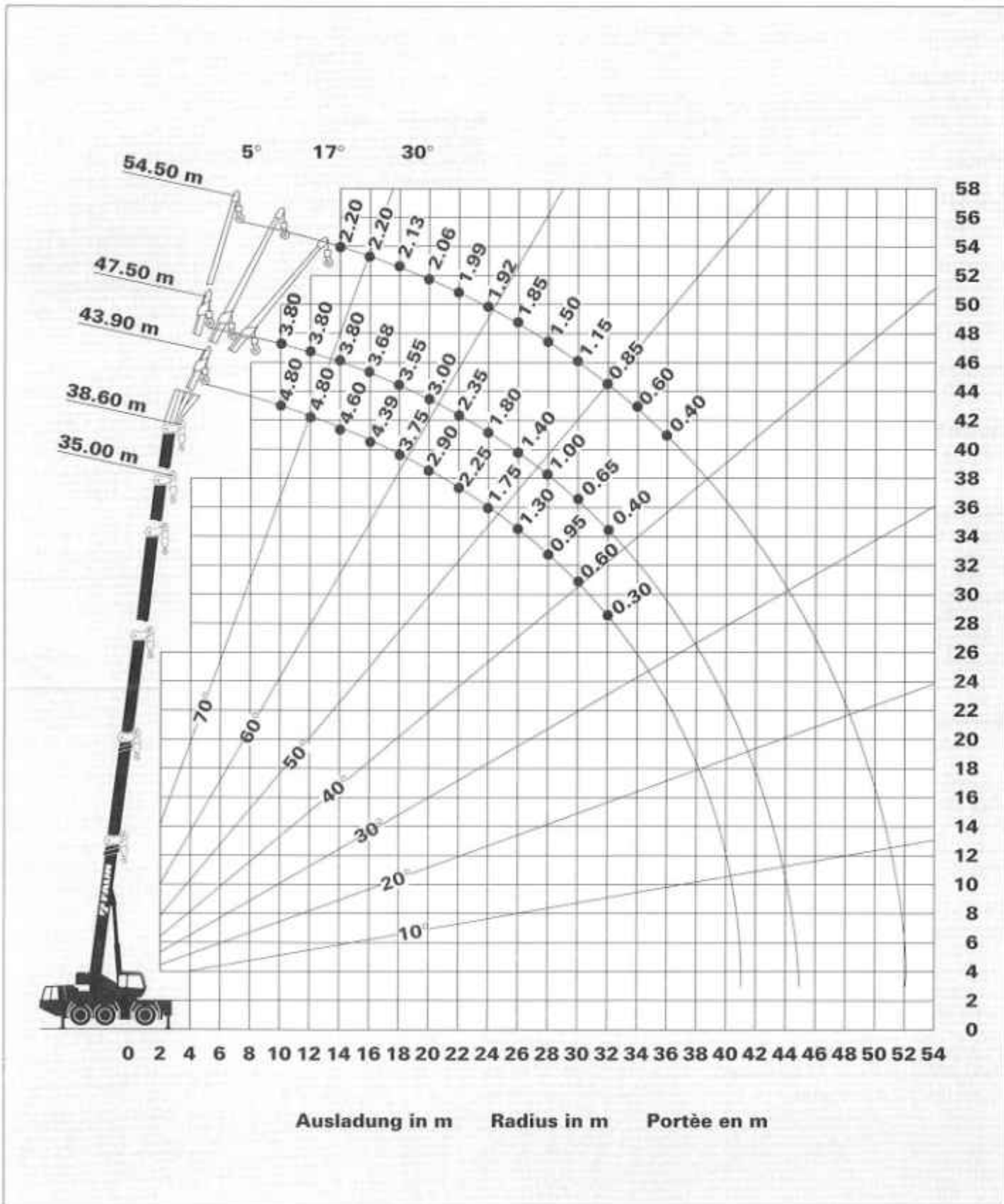

**Rahmen**

Verwindungs- und biegesteife Kastenkonstruktion.

Abstützungen

4-Punkt vollhydraulisch. Betätigung vom Oberwagen sowie links und rechts am Fahrgestell.

Motor

6 Zylinder Mercedes Benz wassergekühlt
OM 441 LA, 250 kW (340 PS bei 2100 U/min.)
Drehmoment: 1450 Nm (148 kpm) bei 1200 U/min.

Getriebe

ZF-Lastschaltgetriebe mit Drehmomentwandler und Lock-up-Kupplung (ab 1. Gang) mit 6 Vorwärts- und 1 Rückwärtsgang.

Achsen

3 lenkbare Planetenachsen mit Differentialsperre.

Antrieb

6x6/6x4 für Gelände
6x2 für Straße

Federung

Hydro-pneumatisch, hydraulisch blockierbar mit Niveauregulierung.

Bremsen

Betriebsbremse: Zweikreis-Druckluft-Bremsanlage.
Feststellbremse: Federspeicher an der 2. und 3. Achse.
Dauerbremse: Konstantdrossel-Anlage und Auspuffklappenbremse.

Bereifung

6fach 16.00 R25

Lenkung

Aus der Fahrgestellkabine: 2-Kreis-Hydro-Halblocklenkung. Mechanische Lenkung der Vorderachsen, hydraulisch unterstützt, mit Notlenkpumpe. Hydrostatische Lenkung aller Achsen aus der Krankabine.

Fahrerhaus

Zweimann Fahrerhaus in Stahl-GFK-Verbundkonstruktion, Sicherheitsverglasung, gefederter und hydraulisch gedämpfter Fahrersitz und motorabhängige Warmwasserheizung. Kontroll- und Bedienungselemente für den Fahrbetrieb.

Elektrische Anlage

24 Volt Gleichstrom, 2 Batterien.
Nach der EG-Regulation.

**Rahmen**

Verwindungssteife Kastenkonstruktion. 1reihige Kugeldrehverbindung außenverzahnt zwischen Fahrgestell und Oberwagen um 360° unbegrenzt drehbar.

Hydrauliksystem

Dreikreis-Hydraulik-Anlage. 1 Axialkolben-Verstell-Doppelpumpe und 1 dreifach Zahnradpumpe angetrieben vom Fahrmotor. Motorleistung im Kranbetrieb 240 kW (326 PS) bei 1800 U/min. (DIN 6270 B).

Steuerung

2 selbstzentrierende Steuerhebel, hydraulische Vorsteuerung.

Wippwerk

1 Differentialzylinder mit angebautem Senkbremsventil.

Drehwerk

Konstant-Motor, zweistufiges Planetengetriebe mit fußbetätigter Betriebsbremse und mit Feststellung. Drehgeschwindigkeit stufenlos von 0-2,5 U/min.

Hubwerk

Axialkolben-Konstantmotor, Hubwerkstrommel mit eingebautem Planetengetriebe und federbelasteter Haltebremse mit integriertem Freilauf.

Teleskopausleger

1 Grundkörper, 4 Teleskopteile. Hydraulisch unter Last teleskopierbar. 10,0-38,6 m lang.

Auslegerverlängerungen*

Teleskop-Spitzenausleger seitlich klappbar, 9,0 / 16,0 m lang, unter 5°/17°/30° montierbar.

Kranfahrerkabine

Seitlich links am Oberwagen. Ganzstahlausführung mit Sicherheitsverglasung, gefederter und hydraulisch gedämpfter, verstellbarer Sitz und motorunabhängige Warmluftheizung. Kontroll- und Bedienungselemente für den Kran- und Fahrbetrieb.

Sicherheitseinrichtungen

Sicherheitsventile gegen Rohr- und Schlauchbruch, Windenendschalter, Windendrehmelder, Lastmomentbegrenzung* und Hubendschalter*.

**Frame**

Torsion and bend resistant box type steel construction.

Outriggers

4 point hydraulic outriggers controlled from upper cab and from both sides of carrier.

Engine

6 cylinder Mercedes Benz water-cooled engine
OM 441 LA, 250 kW (340 HP) at 2100 rpm.
Torque: 1450 Nm (148 kpm) at 1200 rpm.

Transmission

ZF-Powershift transmission with torque converter with lock-up from 1st gear. 6 forward gears and 1 reverse gear.

Axles

3 steering planetary axles with differential locks.

Drive

6x6/6x4 – off road
6x2 – on road

Suspension

Hydro-pneumatic, hydraulically lockable with levelling adjustment.

Brakes

Service brake: Dual circuit air brakes.
Parking brake: Spring loaded acting on 2nd and 3rd axles.
Engine brake: Constant throttle system and engine exhaust brake.

Wheels

6x16.00 R25

Steering

From carrier cab: Dual circuit semi-block. Front two axles mechanically steered with hydraulic assistance and with emergency pump.
From crane cab: all axles hydro-statically steered.

Carrier Cab

Panoramic design. Two man composite construction cab with safety glass and hydraulically cushioned adjustable seat. Controls and instrumentation for driving. Heater (engine dependent).

Electrical System

24 volt DC system with 2 batteries. According to EEC regulations.

**Frame**

All welded torsion resistant steel structure with single row ball-bearing slewing ring with external gears for 360° continuous rotation.

Hydraulic System

Engine driven 3 circuit hydraulic system with one variable displacement axial piston double pump and one triple gear pump. Engine rating for crane work 240 kW (326 HP) at 1800 rpm. (DIN 6270 B).

Controls

2 joy-stick type control levers for simultaneous crane motions, hydraulically controlled.

Boom Hoist

One double acting hydraulic cylinder with integral safety check valve.

Slewing Gear

Constant motor with planetary reduction with foot controlled service brake, automatic holding brake and with parking brake.
Slewing speed 0-2.5 U/min.

Main Winch

Axial piston fixed displacement motor with planetary reduction and spring loaded multiple disc holding brake.

Telescopic boom

1 boom base and 4 telescoping sections. All sections hydraulically extendable under load. 10,0 m - 38,6 m long.

Boom Extension*

2-stage telescopic extension 9.0 m / 16.0 m. Offsets 5°/17°/30°.

Crane Cab

Left hand mounted Panoramic design. Spacious all-steel structure with special safety glass, hydraulically cushioned adjustable seat and independent hot-air heater. Controls and instrumentation for crane operation and travelling.

Safety Devices

Safety valves against hose and pipe rupture, main winch limit switch and main winch drum turn indicator. Electronic load moment device* and anti-two block device*.



Châssis

Construction mécano-soudée, en forme de caisson, résistante aux flexions et aux torsions.

Calage

4 poutres extensibles hydrauliquement à partir de la cabine du grutier et latéralement à gauche et à droite du châssis.

Moteur

Mercedes-Benz diesel OM 441 LA, 250 kW (340 CV à 2100 tr/min) refroidi par eau.

Couple-moteur: 1450 (148 kpm) Nm à 1200 tr/min.

Boîte de vitesses

Boîte powershift ZF avec convertisseur de couple et embrayage lock-up (à partir de 1ère vitesse) avec 6 vitesses AV et 1 AR.

Essieux

Les 3 essieux planétaires avec blocage différentiel et directeur.

Entraînement

6x6/6x4 en tout-terrain

6x2 sur la route.

Suspension

Hydro-pneumatique, réglage d'inclinaison à suspension bloquée.

Freins

Frein de service: système de frein à air comprimé à double circuit.

Frein de parage: Frein à accumulateur à ressorts sur 2ème et 3ème essieu.

Frein permanent: Ralentisseur et clapet d'échappement à commande pneumatique.

Pneumatiques

6 pneus de 16.00R25

Direction

Direction hydraulique semi-bloc à 2 circuits depuis la cabine du conducteur. Direction mécanique des essieux avant, avec pompe hydr. de secours. Direction hydrostatique des 3 essieux à partir de la cabine tourelle.

Cabine de Conducteur

Cabine bi-place, construction en matière combinée, avec vitrage en verre de sécurité, siège du conducteur à ressort et amorti hydrauliquement. Chauffage à eau chaude dépendant du moteur. Tableau de bord avec instruments de contrôle et conduite.

Système électrique

24 V courant continu, 2 batteries, conforme aux normes CEE.



Plate forme

Construction mécano-soudée, résistant à la torsion. Couronne d'orientation avec denture extérieure, permettant une rotation illimitée à 360°.

Système hydraulique

Diesel-hydraulique, installation hydraulique à 3 circuits, 1 pompe double à piston type axiale (réglage hydraulique) 1 pompe triple à engrenages entraînée par le moteur porteur. Puissance du moteur pendant le travail de levage 240 kW (326 CV) à 1800 tr/min. (DIN 6270 B).

Commandes

2 leviers à commande manuelle universelle et à autocentrage, assistés hydrauliquement.

Mécanisme de relevage

Vérin différentiel muni de clapet de sécurité.

Mécanisme de rotation

Moteur à débit continu avec entraînement planétaire biétagé. Frein de service actionné par l'intermédiaire d'une pédale et avec arrêt. Vitesse de rotation 0 à 2.5 tr/min.

Mécanisme de levage

Moteur hydraulique, tambour de levage avec boîte planétaire incorporée, frein d'arrêt à disques multiples à ressort, libéré lors du levage.

Flèche télescopique

1 élément de base et 4 éléments télescopiques, télescopables en charge. Longueur 10,0 m à 38,6 m.

Rallonge de flèche*

Construction en treillis avec rallonge mécanique de 9.0 m à 16.0 m, rabattable latéralement et inclinable à 5°/17°/30°.

Cabine de conduite

Montée du côté gauche. En acier avec vitrage de sécurité, siège suspendu sur ressorts, amorti hydrauliquement et réglable. Chauffage à air chaud indépendant du moteur. Tableau de bord avec instruments de contrôle et de conduite.

Dispositifs de sécurité





Clapets anti-retour contre l'éventuelle rupture des conduites ou flexibles, interrupteur de fin de course du treuil pour câble de levage sur le tambour, indicateur du nombre de tours sur tambour de treuil, limiteur de couple de charge*, interrupteur de fin de course de levage*.

034/05/XII 95/4/d.e.fBi

HOW TO CALL GERMANY:

(A)	from/to	 TADANO FAUN	0 60
(B)	(CH) (I)	 TADANO FAUN	00 49
(DK)	(S)	 TADANO FAUN	0 09 49
(E)		 TADANO FAUN	07 49
(F)		 TADANO FAUN	19 49
(GB)		 TADANO FAUN	0 10 49
(N)		 TADANO FAUN	0 95 49
(NL)		 TADANO FAUN	00 49

NIGHT & DAY

		(0) 91 23 95 50
		(0) 17 18 11 43 24
		(0) 91 23 18 51 55
		(0) 91 23 18 52 19

24h

STUNDEN

SERVICE

 **622 990**